

ISSN 0370-2197

**ПРОБЛЕМИ
ТЕРТЯ ТА
ЗНОШУВАННЯ**

**PROBLEMS OF
FRICTION AND WEAR**

2(107).2025

ЗМІСТ

<i>КХИМКО А., МИКОСІАНЧУК О., МНАЦАКАНОВ Р., БЕСПАЛОВС., ТОКАРУК В.</i> Analysis of damage to aircraft parts made of titanium alloys and increase of their wear resistance by gas-thermal coatings.....	4
<i>КАРУСКЕВИЧ М.В., КОПЧУК О.Ю., КАРУСКЕВИЧ О.М., КОПЧУК В.І.</i> Методики дослідження стадій зародження і розповсюдження тріщин в алюмінієвих сплавах в умовах дії поверхнево-активних речовин.....	11
<i>KINDRACHUK M. V., KHARCHENKO V. V., YURCHUK A. O., STEBELETSKA N. M.</i> Improving the wear resistance of titanium alloys by thermal spraying methods.....	19
<i>BRESHEV O.V., BASHTA O.V., NOSKO P.L., BASHTA A.O., SPIVAK O.M., SEMAK I.V.</i> Development of a design scheme of a single-support drive system with aerostatic bearings.....	25
<i>BRESHEV O.V., NOSKO P.L., BASHTA O.V., BASHTA A.O., RADKO M.O., HERASYMOV V.O.</i> Parameters and characteristics of a single-support drive system with tapered aerostatic bearings.....	32
<i>МИКОСІАНЧУК О. О., СКВОРЦОВ О. О., КОРНИЄНКО А. О.</i> Improving the wear resistance of structural steels by electrospark deposition.....	40
<i>ЖУРАВЛЬОВ Д. Ю., ВАСИЛИШИН Я. В., ВАСИЛИШИН В. Я., ЧУФУС В. М., ПРИСЯЖНИЙ А. В., ПІЦУК В. В.</i> Оптимізація конструктивних і режимних параметрів при експлуатації пар тертя гальм.....	48
<i>РУТКОВСЬКИЙ А., ЛОПАТА О., РАДЬКО О., МАРКОВИЧ С., КАТЕРИНИЧ С., СОЛОВИХ А.</i> Дослідження процесу вакуумного термоциклічного азотування у плазмі пульсуючого тліючого розряду.....	62
<i>МАЛІНОВСЬКИЙ Ю. О., ВЛАСЕНКОВ Д. П., ОЛІЙНИК С. Ю., СИТНИК С. О., ШЕВЧЕНКО О. А., БОНДАРЕЦЬ А. О.</i> Передумови до руйнування поверхневих шарів деталей під час їх тертя та зношування.....	76
<i>BOGDAN S. Y., BOGDAN D. V.</i> Analysis of fiber-reinforced elements from composite materials.....	97
<i>TAMARGAZIN O., PRYIMAK L., MORSHCH I.</i> Influence of thermal regime on the structural-phase state of coatings based on 11P3AMФ2 steel.....	105
<i>СЕМАК І. В., БОРОЗЕНЕЦЬ Г. М.</i> Дослідження впливу ударної дії граду на міцність вуглепластиків авіаційних конструкцій.....	114
<i>SHEVCHENKO O. A., ANDRIETS O. G., ROHOZHYN A. O.</i> Damage of carbon plastics from low-velocity impact and their relaxation.....	121

КХИМКО А., МИКОСІАНЧУК О.
Analysis of damage to aircraft parts made of titanium alloys and increase of their wear resistance by gas-thermal coatings.....

КАРУСКЕВИЧ М.В., КОПЧУК О.Ю., КАРУСКЕВИЧ О.М., КОПЧУК В.І.
Methods for studying the damage of titanium alloys to surfactants.....

KINDRACHUK M. V., KHARCHENKO V. V., YURCHUK A. O., STEBELETSKA N. M.
Improving the wear resistance of titanium alloys by thermal spraying methods.....

BRESHEV O.V., BASHTA O.V., NOSKO P.L., BASHTA A.O., SPIVAK O.M., SEMAK I.V.
Development of a design scheme of a single-support drive system with aerostatic bearings.....

BRESHEV O.V., NOSKO P.L., BASHTA O.V., BASHTA A.O., RADKO M.O., HERASYMOV V.O.
Parameters and characteristics of a single-support drive system with tapered aerostatic bearings.....

МИКОСІАНЧУК О. О., СКВОРЦОВ О. О., КОРНИЄНКО А. О.
Improving the wear resistance of structural steels by electrospark deposition.....

ЖУРАВЛЬОВ Д. Ю., ВАСИЛИШИН Я. В., ВАСИЛИШИН В. Я., ЧУФУС В. М., ПРИСЯЖНИЙ А. В., ПІЦУК В. В.
Optimization of design parameters and operating modes of tribopairs.....

РУТКОВСЬКИЙ А., ЛОПАТА О., РАДЬКО О., МАРКОВИЧ С., КАТЕРИНИЧ С., СОЛОВИХ А.
Research of the vacuum plasma nitriding process of pulsed glow discharge.....

МАЛІНОВСЬКИЙ Ю. О., ВЛАСЕНКОВ Д. П., ОЛІЙНИК С. Ю., СИТНИК С. О., ШЕВЧЕНКО О. А., БОНДАРЕЦЬ А. О.
Prerequisites for the destruction of surface layers of parts during friction and wear.....

BOGDAN S. Y., BOGDAN D. V.
Analysis of fiber-reinforced elements from composite materials.....

TAMARGAZIN O., PRYIMAK L., MORSHCH I.
Influence of thermal regime on the structural-phase state of coatings based on 11P3AMФ2 steel.....

СЕМАК І. В., БОРОЗЕНЕЦЬ Г. М.
Investigation of the damage of carbon plastics from low-velocity impact and their relaxation.....

SHEVCHENKO O. A., ANDRIETS O. G., ROHOZHYN A. O.
Damage of carbon plastics from low-velocity impact and their relaxation.....

UDC 621.891 (043.3)

DOI: 10.18372/0370-2197.2(107).20143

O.V. BRESHEV¹, P.L. NOSKO¹, O.V. BASHTA¹, A.O. BASHTA², M.O. RADKO¹,
V.O. HERASYMOV¹

¹State University "Kyiv Aviation Institute", Ukraine

²National University of Food Technologies, Ukraine

PARAMETERS AND CHARACTERISTICS OF A SINGLE-SUPPORT DRIVE SYSTEM WITH TAPERED AEROSTATIC BEARINGS

A theoretical analysis of a single-point drive system with aerostatic bearings is presented in this study, focusing on the selection and modeling of flow control devices, in particular, annular diaphragms. The paper derives a dimensionless operating parameter that relates the pressure drops between the lubricating film and the flow control device, taking into account the properties of the gas and the bearing geometry. A set of standardized formulas is used to determine the stiffness and lift coefficients for subcritical laminar flow conditions. The model takes into account the influence of conical bearing surfaces, which allows calculating radial and axial load capacities, as well as ultimate moment loads. The results demonstrate a significant dependence of performance on the average air gap and discharge pressure. Thus, the simultaneous adjustment of these parameters can increase the bearing load capacity by up to 24 times, while the practical functionality is maintained within a more limited range of approximately three times the variability.

Keywords: aerostatic bearing, single-support system, diaphragm, flow restrictor, gas lubrication, supply pressure, average clearance, laminar regime.

Introduction. One of the important points in the design calculation of a single-support drive system with aerostatic bearings (Fig. 1) is the choice of the type of air flow restrictors that create a pressure drop between the annular supercharging chamber and the lubricating layer. This difference ($p_s - p_d$) is not known in advance. The drive system with aerostatic bearings can be determined by the limiter (p_d), and the pressure distribution (p) throughout the lubricating layer can be set using it. Let us use an annular diaphragm as a restrictor, for which the following empirical condition must be fulfilled.

Presentation of the main material and discussion on the research results. The dimensionless mode parameter \bar{m} characterizes the ratio of pressure drops along the lubricating layer ($p_d - p_a$) and across the flow restrictor ($p_s - p_d$), depending on the design features of the support and the properties of the supplied gas:

$$\bar{m} = \frac{B n_d N D_d}{C^2 p_s} \quad (1)$$

where C is the average gap at zero eccentricity;

N is the number of holes in one row of nozzles;

n_d is the number of rows of nozzles;

B is a coefficient that depends only on the properties and temperature of the gas, which is determined by the formula:

$$B = 12\mu a \left(\frac{2}{k+1} \right)^{\frac{k+1}{2(k-1)}},$$

where μ is the air viscosity;

a is the speed of sound;

k is the adiabatic coefficient (for two-atom gases and air it is equal to 1.4).

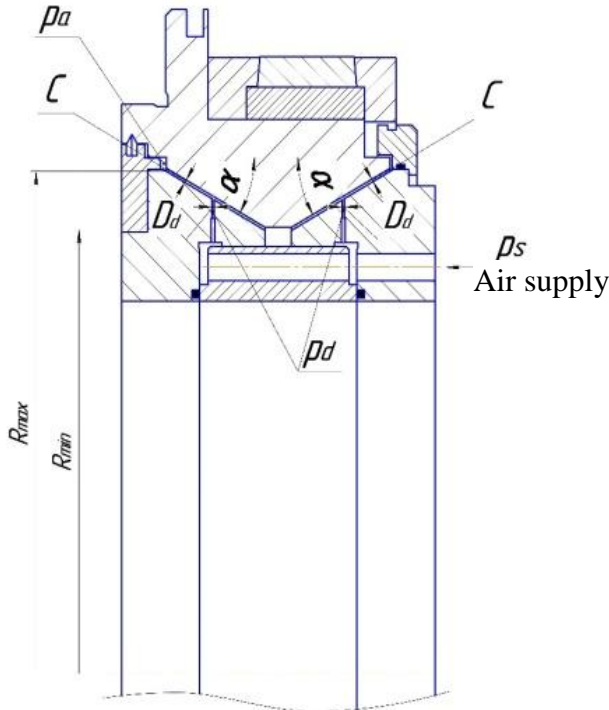

Fig. 1. Single support system on an aerostatic bearing.

The expression $\left(\frac{2}{k+1}\right)^{\frac{k+1}{2(k-1)}}$ in works [1, 2] is denoted by the adiabatic function $F(k)$.

Taking into account the above provisions, we obtain the final formula for calculating the aerostatic support mode parameter:

$$\bar{m} = \frac{12\mu a \left(\frac{2}{k+1}\right)^{\frac{k+1}{2(k-1)}} N n_d D_d}{C^2 p_s}.$$

In accordance with the recommendations of [4], the obtained value of \bar{m} should be multiplied by the flow correction factor α_p , which for annular diaphragms is 0.8. The necessary data for further calculation are relative pressure \bar{p}_a and relative backpressure \bar{p}_d .

The first one expresses the ratio of the external (atmospheric) pressure p_a to the air supply pressure p_s on the nozzles. The relative backpressure is the ratio of the pressure at the outlet of the nozzle p_d into the lubricating layer to the supply pressure p_s of the process air and is determined through the function ζ by Prandtl approximation [3]:

$$\bar{p}_d = \sqrt{\left(\frac{-2}{\bar{p}_a + \bar{m}\zeta} \sqrt{1 + (\bar{m}\zeta)^2} - \bar{p}_a\right) \div \left(1 + (\bar{m}\zeta)^2\right)} \quad (2)$$

where ζ is a function that depends on the geometric parameters of the support (relative length of the bearing - λ and relative spacing of the boost lines $b = l^*/L$):

$$\zeta = \frac{\lambda(1-b)}{2}.$$

The rate of air leakage through the nozzles is determined by the pressures p_d and p_s or by one dimensionless value \bar{p}_d :

$$\bar{p}_d = \left(\frac{2}{k+1} \right)^{\frac{k}{k-1}}.$$

As the pressure differential increases, the air flow rate increases and reaches the speed of sound at a certain (critical) value. If $\bar{p}_d \leq 0.528$, then the flow rate exceeds the speed of sound, and compression surges can occur, which are characterized by energy absorption and local pressure drops. For this reason, gas flow regimes through the feeders must be subcritical. Typically, in aerostatic air supports, $0.528 < p_d < 0.9$.

The calculation of the counterpressure according to formula (2) for the considered support under the condition that $p_a = 1$ atm requires a reduction in the boost pressure to values that ensure $0.528 < p_d < 0.9$, since the occurrence of a critical supersonic regime does not guarantee stable operation of the support.

To calculate the stiffness coefficients of the support, we use standardized formulas:

$$\bar{K}_r^e = \frac{C}{4\lambda R^2 p_s} K_r^e = \frac{0,75\pi v}{ch\lambda + 0.5\bar{m}U_r \cdot chb\lambda \cdot sh\bar{b}\lambda} \times \left(\frac{shb\lambda \cdot sh\bar{b}\lambda}{\lambda \bar{p}_d} + I_0 \frac{chb\lambda}{\sqrt{v\lambda}} \right); \quad (3)$$

$$\bar{K}^y = \frac{C}{4\lambda^2 R^4 p_s} K^y = \frac{0,75\pi}{\lambda} \times \left[\frac{2}{3} \left[(2+b)\bar{p}_d - 3\bar{p}_a + \frac{2b\bar{p}_a^2}{\bar{p}_d + \bar{p}_a} \right] + \frac{v\eta}{\lambda} \left(b \cdot chb\lambda - \frac{shb\lambda}{\lambda} \right) - \sqrt{v\lambda} \left[I_1 - \left(th \frac{\bar{b}\lambda}{2} + \eta \frac{shb\lambda}{sh\bar{b}\lambda} \right) I_2 \right] \right], \quad (4)$$

where $\bar{b} = 1 - b$; i is a constant equal to $2/3$;

$$v = \frac{\bar{p}_d - \bar{p}_a}{\lambda b};$$

U_r is the Prandtl approximation of the leakage function, which in the considered case has the following form: $U_r = \frac{1}{2 p_d}$;

$$\eta = \frac{ib\lambda \cdot sh\bar{b}\lambda + ch\bar{b}\lambda - 1}{sh\lambda + 0.5\bar{m}U_r \cdot shb\lambda \cdot sh\bar{b}\lambda} \text{ is a complex coefficient;}$$

I_0, I_1, I_2 is a series of similar integrals, the solution of which has the form:

$$I_0 = \int_b^1 \frac{sh\lambda(1-x)}{\sqrt{\beta-x}} dx ;$$

$$\begin{bmatrix} I_1 \\ I_2 \end{bmatrix} = \int_b^1 \frac{x}{\sqrt{\beta-x}} \begin{bmatrix} ch\lambda(1-x) \\ sh\lambda(1-x) \end{bmatrix} dx .$$

To calculate the lifting force of a single-support system within the framework of the linear formulation of the problem, we use equation:

$$W_r = \lambda A_\Sigma \cdot p_s \cdot \bar{W}_r = \lambda A_\Sigma p_s \bar{K}_r \varepsilon_r \quad (5)$$

where $A_\Sigma = 4R^2$ is the global scale of the area;

$\varepsilon_r = \frac{e}{C}$ global scale area-relative eccentricity, the maximum value of which corresponds to the ultimate load capacity of the support and can reach a value of 0.8 - 0.9, so that the residual clearance would be at least 2...3 microns;

The ultimate moment load on the support M_γ is determined, in fact, by the restoring aerodynamic moment, which is a linear function of the angle of rotation of the axis of the movable part of the support:

$$M_\gamma = \bar{K}^\gamma \cdot \bar{\gamma} \cdot 4\lambda \cdot R^3 p_s \quad (6)$$

where $\bar{\gamma} = \frac{\lambda R}{C} \gamma$ is the bearing angular misalignment coefficient;

γ is the axis misalignment angle of the aerostatic bearing.

In the considered single-support system $R = (R_{min} - R_{max})/2$, a radial thrust bearing with tapered contact surfaces located at an angle α to the axis of rotation is used, so the resulting effect of gas lubrication is directed at the same angle to the radial direction (perpendicular to the surface). The bearing capacity W_{rky} is determined by the radial component (longitudinal OY) of the gas lubrication reactions:

$$W_{rky} = W_r \cdot \cos\alpha . \quad (7)$$

The bearing capacity in the axial direction, W_{rkz} , also depends on W_r and α , but, given that the tapered surfaces are directed towards each other, the axial load of either direction is perceived only by that half of the bearing that is located in the direction of the load.

Therefore, the load-carrying capacity of a radial contact bearing W_{rkz} is determined by half of the sum of the axial components (along the OZ axis) of the gas lubricant reactions:

$$W_{rkz} = \frac{1}{2} W_r \cdot \sin\alpha . \quad (8)$$

Limit (at $\bar{p}_a \rightarrow 0$) volumetric flow rate Q [m³/h] of gas lubrication through the support, adjusted to normal conditions:

$$Q = \frac{\pi C^3 p_s^2}{12\mu p_a} \cdot \bar{m} \cdot 3600. \quad (9)$$

The results of the single-support aerostatic system main parameters calculations, in accordance with (1)-(9), for various value of the average clearance C with air lubrication and fulfilling the conditions of the subcritical and laminar regime of air-lubrication flow are given in Table 1.

The obtained results showed a significant effect on the radial W_{rky} and axial W_{rkz} load-carrying capacities and ultimate moment load M_γ of the values of the average clearance C and the pressure p_s of the process air supply to the feeders.

While adjustment of the process air supply pressure p_s is not a technical problem and is frequently used in practice, the adjustment of the support by the clearance value during operation is possible only for tapered aerostatic supports and is technically much more difficult to implement. With the simultaneous adjustment of aerostatic supports by these two parameters in the widest possible range, it becomes theoretically possible to increase W_{rky} and W_{rkz} by about 23...24 times (the corresponding stiffnesses change at a similar level), and M_γ more than 40 times.

If we consider the adjustability of the aerostatic bearing within the limits of ensuring the guaranteed functionality of the spindle assembly, the range is narrowed by about 3 times. The highlighted rows of Table 1 include the maximum and minimum values of the characteristics at which the spindle assembly will remain operable, and their increment will be up to 8 times.

Table 1

Changing the parameters of a single-support system by varying the average clearance and boost pressure

Average clearance with air lubrication C , m	Supply pressure to the feeders p_s , MPa	Load-carrying capacity of a single support system		Maximum moment load M_γ , N·m	Air consumption Q , m ³ /h
		in the radial direction W_{rky} , N	in the axial direction W_{rkz} , N		
10×10^{-6}	0.69	8192	2364	26716	2.4
15×10^{-6}	0.38	2524	728	6470	2.0
20×10^{-6}	0.29	1131	327	2468	2.1
25×10^{-6}	0.25	600	173	1177	2.2
30×10^{-6}	0.22	335	97	611	2.3

Conclusion

It was found that changes in air supply pressure and average clearance significantly affect the load-carrying capacity and stiffness of the support. Optimization of these parameters can increase the efficiency of aerostatic bearings in air-lubricated spindle assemblies.

References

- Allen, D. & Stokes, P. & Whitley, S. (1961). The Performance of Externally Pressurized Bearings Using Simple Orifice Restrictors. *Asle transactions*. 4. 181-196. DOI:10.1080/05698196108972430.
- Breshev, V. E. Issledovanie vliyaniya na ustojchivost dvizheniya rabochih organov mashin sposobov prilozheniya vneshnej nagruzki [Tekst] / V. E. Breshev, A. E. Tretyak //

Praci Luganskogo viddilennya Mizhnarodnoyi Akademiyi informatizaciyi. – 2007. – № 2 (15) Ch.II. – S. 10 – 12.

3. Faria, Marco. (2014). A Comparative Performance Analysis of Gas Lubricated Cylindrical and Elliptical Journal Bearings. *International Review of Mechanical Engineering (IREME)*. 8. 901. DOI:10.15866/ireme.v8i5.2985.

4. Matsushita, Osami & Tanaka, Masato & Kobayashi, Masao & Keogh, P.s & Kanki, Hiroshi. (2019). Basics of Plain Bearings. DOI:10.1007/978-4-431-55453-0_2.

Стаття надійшла до редакції 19.05.2025

Breshev Oleksii Volodymyrovych - PhD in Engineering, Department of Applied Mechanics and Materials Engineering, State University “Kyiv Aviation Institute”, Ukraine, 1, Lubomyr Huzar Ave., Kyiv, Ukraine, 03058, E-mail: abreshev@gmail.com, <https://orcid.org/0009-0007-4176-775X>

Nosko Pavlo Leonidovych - Doctor of Technical Sciences, Professor, Professor of the Department of Applied Mechanics and Materials Engineering, State University “Kyiv Aviation Institute”, 1, Lubomyr Huzar Ave., Kyiv, Ukraine, 03058, tel. 406-78-42, E-mail: nau12@ukr.net, <https://orcid.org/0000-0003-4792-6460>

Bashta Oleksandr Vasylovych - PhD in Engineering, Associate Professor, Department of Applied Mechanics and Materials Engineering, State University “Kyiv Aviation Institute”, 1, Lubomyr Huzar Ave., Kyiv, Ukraine, 03058, E-mail: oleksandr.bashta@npp.kai.edu.ua, <https://orcid.org/0000-0001-7914-897X>

Bashta Alla Oleksiivna - PhD in Engineering, Associate Professor, Department of Health Products Technology, National University of Food Technologies, 68 Volodymyrska str. Kyiv, Ukraine, 01601, tel. 289-54-72, <https://orcid.org/0000-0003-0310-3788>

Radko Maksym Olehovych - Graduate of higher education with a master's degree in specialty 131 “Applied Mechanics”, educational and professional program “Applied Mechanics, Standardization and Quality Assessment of Technical Systems”, State University “Kyiv Aviation Institute”, 1, Lubomyr Huzar Ave., Kyiv, Ukraine, 03058, tel. 406-78-42, E-mail: nau12@ukr.net

Herasymov Volodymyr Olehovych - Graduate of higher education with a master's degree in specialty 131 “Applied Mechanics”, educational and professional program “Applied Mechanics, Standardization and Quality Assessment of Technical Systems”, State University “Kyiv Aviation Institute”, 1, Lubomyr Huzar Ave., Kyiv, Ukraine, 03058, tel. 406-78-42, E-mail: nau12@ukr.net

О.В. БРЕШЕВ, П.Л. НОСКО, О.В. БАШТА, А.О. БАШТА, М.О. РАДЬКО,
В.О. ГЕРАСИМОВ

ПАРАМЕТРИ І ХАРАКТЕРИСТИКИ ОДНООПОРНОЇ СИСТЕМИ ПРИВОДУ З КОНІЧНИМИ АЕРОСТАТИЧНИМИ ПІДШИПНИКАМИ

У роботі представлено теоретичний аналіз одноточкової приводної системи з аеростатичними підшипниками з акцентом на виборі та моделюванні пристроїв керування потоком, зокрема, кільцевих діафрагм. Виведено безрозмірний робочий параметр, який пов'язує перепади тиску між змащувальною плівкою і пристроєм регулювання потоку з урахуванням властивостей газу і геометрії підшипника. Для визначення коефіцієнтів жорсткості та підйомної сили для докритичних ламінарних умов течії використовується набір стандартизованих формул. Модель враховує вплив конічних опорних поверхонь, що дозволяє розраховувати радіальну та осьову вантажопідйомність, а також граничні моментні навантаження. Результати демонструють значну залежність продуктивності від середнього повітряного зазору і тиску нагнітання. Таким чином, одночасне регулювання цих параметрів може збільшити несучу здатність підшипника до 24 разів, в той час як практична функціональність зберігається в більш обмеженому діапазоні приблизно втричі більшої варіабельності.

Ключові слова: аеростатичний підшипник, одноопорна система, діафрагма, обмежувач витрати, газове мастило, тиск подачі, середній зазор, ламінарний режим.

Список літератури

1. Allen, D. & Stokes, P. & Whitley, S. (1961). The Performance of Externally Pressurized Bearings Using Simple Orifice Restrictors. *Asle transactions*. 4. 181-196. DOI:10.1080/05698196108972430.
2. Breshev, V. E. Issledovanie vliyaniya na ustojchivost dvizheniya rabochih organov mashin sposobov prilozheniya vneshnej nagruzki [Tekst] / V. E. Breshev, A. E. Tretyak // Praci Luganskogo viddilennya Mizhnarodnoyi Akademiyi informatizaciyi. – 2007. – № 2 (15) Ch.II. – S. 10 – 12.
3. Faria, Marco. (2014). A Comparative Performance Analysis of Gas Lubricated Cylindrical and Elliptical Journal Bearings. *International Review of Mechanical Engineering (IREME)*. 8. 901. DOI:10.15866/ireme.v8i5.2985.
4. Matsushita, Osami & Tanaka, Masato & Kobayashi, Masao & Keogh, P.s & Kanki, Hiroshi. (2019). Basics of Plain Bearings. DOI:10.1007/978-4-431-55453-0_2.

Брешев Олексій Володимирович - кандидат технічних наук, кафедра прикладної механіки та інженерії матеріалів, Державний університет «Київський авіаційний інститут», Україна, пр-т Любомира Гузара, 1, м. Київ, Україна, 03058, E-mail: abreshev@gmail.com, <https://orcid.org/0009-0007-4176-775X>

Носко Павло Леонідович - доктор технічних наук, професор, професор кафедри прикладної механіки та інженерії матеріалів, Державний університет «Київський авіаційний інститут», пр-т Любомира Гузара, 1, м. Київ, Україна, 03058, тел. 406-78-42, E-mail: nau12@ukr.net, <https://orcid.org/0000-0003-4792-6460>

Башта Олександр Васильович - кандидат технічних наук, доцент, кафедра прикладної механіки та інженерії матеріалів, Державний університет «Київський авіаційний інститут», пр-т Любомира Гузара, 1, м. Київ, Україна, 03058, E-mail: oleksandr.bashta@npp.kai.edu.ua, <https://orcid.org/0000-0001-7914-897X>

Башта Алла Олексіївна - кандидат технічних наук, доцент, кафедра технології оздоровчих продуктів, Національний університет харчових технологій, вул. Володимирська, 68. Київ, Україна, 01601, тел. 289-54-72, <https://orcid.org/0000-0003-0310-3788>

Радько Максим Олегович - здобувач вищої освіти ступеня магістра за спеціальністю 131 «Прикладна механіка», освітньо-професійна програма «Прикладна механіка, стандартизація та оцінка якості технічних систем», Державний університет «Київський авіаційний інститут», пр-т Любомира Гузара, 1, м. Київ, Україна, 03058, тел.. 406-78-42, E-mail: nau12@ukr.net

Герасимов Володимир Олегович - здобувач вищої освіти ступеня магістра зі спеціальності 131 «Прикладна механіка», освітньо-професійна програма «Прикладна механіка, стандартизація та оцінка якості технічних систем», Державний університет «Київський авіаційний інститут», пр-т Любомира Гузара, 1, м. Київ, Україна, 03058, тел.. 406-78-42, E-mail: nau12@ukr.net