

EFFECT OF TEMPERATURE ON THE PROCESS OF PRESSING ORGANIC RAW MATERIALS

D.V. Rindyuk, N.V. Ryabokon

National university of food technologies, Ukraine, Kiev

Abstract: The process of extrusion pelletizing particulate materials, such as sunflower and buckwheat husk, oak and pine chips, wheat straw and bran has been considered. It was investigated the effect of temperature of raw materials, compacting pressure and the diameter of the press-matrix on quality of fuel pellets.

Keywords: temperature, particulate materials, biofuels, pelleting.

I. Introduction

Production of solid biofuels is an urgent requirement for fuel and energy complex of any developed country in the world, and therefore there is a requirement for research that would allow discovering the peculiarities of the process with granulation of fuel pellets.

In article [1] the problem of determining the optimal technical and technological parameters of the process of granulation extrusion was treated and was got the disperse of materials obtained depending influence of the main parameters of unit pressed pellet (Fig. 1) on the quality of the final product – the pellet.

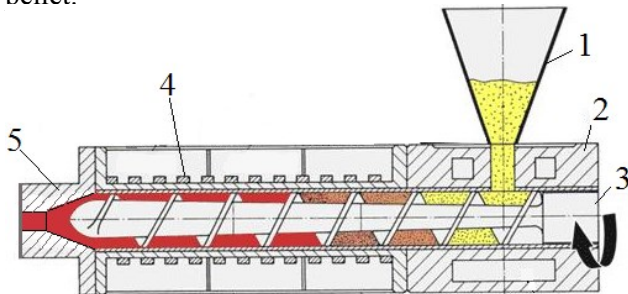

Figure 1. Scheme of node compression screw extruder-granulator (1 – bunker, 2 - cylinder, 3 – screw, 4 – heater, 5 - forming head).

Regardless of the hardware design at process of granulation significant influence on the formation of granules of a material which has been granulated: raising of the temperature increases the density of granules, and also reduces energy consumption in the process of pressing [2].

The basic constituents of raw materials for solid biofuels are cellulose, hemicellulose and lignin. Lignin as an amorphous polymer is a kind of binding between cellulose fibrils, providing strength and rigidity of the cell wall (if cellulose with properties corresponding fixture, the lignin, which has a high compressive strength - concrete).

At low temperature processes (up to 160 ° C) reaction hydrolytic decomposition of carbohydrate

content and partial impolymerization of lignin to form low molecular weight fragments are predominant. Rising of the temperature of the process increases the degree of degradation of wood carbohydrates, and yet with lignin impolymerization reactions begins to compete re-polymerization his reaction.

Therefore, attached to change of the temperature of the process to 150-170 ° C of lignin in wood decreases with increasing temperature and process of lignin increases markedly, reaching 33-36% [3-7].

The aim of this work is to study the effect of temperature on the material quality (density) of the final product (pellets) considering structural and technological parameters of the equipment for its compaction during pressing extrusion.

II. Materials and methods

To solve this problem a multifactorial experiment is proposed and to develop mathematical and statistical model of dependence of density fuel pellets produced from sunflower and buckwheat hulls, oak and pine shavings, wheat straw and bran from raw temperature, pressure and pressing channel diameter press-matrix.

$$\rho = f(t, P, d),$$

where

ρ - density of pellets, kg/m³;
 t - temperature materials, ° C;
 P - pressure compression, MPa;
 d - diameter of the press matrix.

Factorial experiment of second order, which is used to describe non-linear objects, in our case, is represented by polynomial [8]:

$$y = b_0 + b_1x_1 + b_2x_2 + b_3x_3 + b_4x_1x_2 + b_5x_1x_3 + b_6x_2x_3 + b_7x_1x_2x_3 + b_8x_1^2 + b_9x_2^2 + b_{10}x_3^2$$

In Figure 2. a scheme of pilot plant for studying the influence of temperature on the process of pressing the materials is represented.

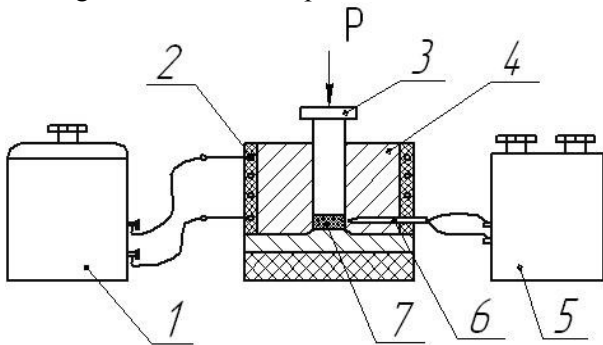

Figure 2. A scheme of pilot plant
 1 - autotransformer 2 - electric heating coil, 3 - punch, 4 - press matrix, 5 – potentiometer, 6 - thermocouple, 7 – sample

Pressing is performing by using of a hydraulic press to press the matrix 4 with varying diameter punch 8–40 mm at a speed of pressing 0,005 m/s. Temperature press-matrix regulate by changing the voltage filed in the electric spiral 2 of isolated press-matrix 4. The temperature of press-matrix is measured by thermocouple 6, potentiometer connected to the direct current 5. Pressure was measured by a manometer.

The experiment was conducted for the following types of materials: sunflower and buckwheat husk, oak and pine chips, wheat straw and bran.

III. Results and discussion

The analysis of the represented dependences showed that with increasing of temperature of the raw materials from 20 to 160 ° C increasing the density of obtained granules is observed. This is due to the intensification of the process of dissolution of lignin with increasing temperature.

It should be noted that a further increasing in temperature of material over 160 ° C is not appropriate because it has a little effect on increasing the density of granules, and thus leads to unnecessary energy costs. Also it is experimentally confirmed that the increase in compacting pressure and decreasing of diameter of press-matrix provides density increase granules.

Table 1. Intervals of variation

Intervals of variation	x_1 (t, °C)	x_2 (P, MPa)	x_3 (d, m)
Zero level	100	175	0,024
Step of variation	80	125	0,016
The lower level	20	50	0,008
The upper level	180	300	0,04

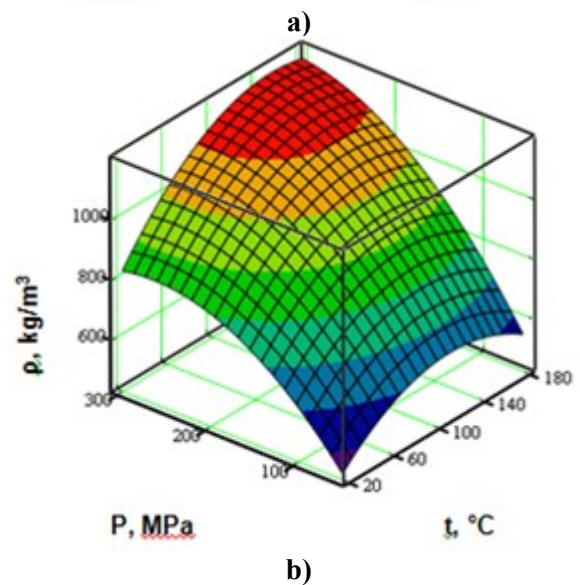
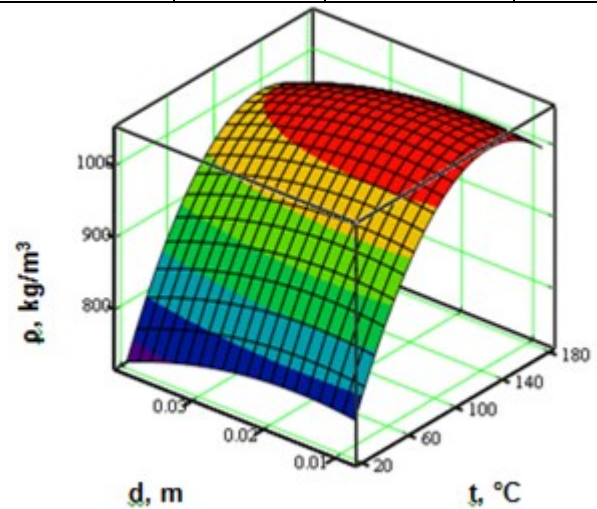

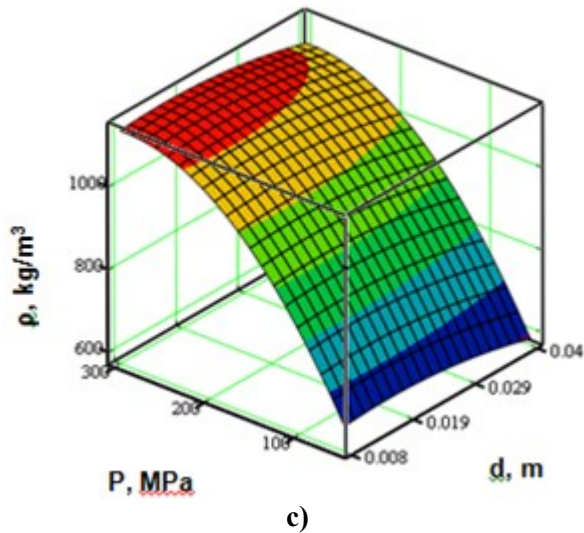

Figure 3. The dependence of the density of granules (husk of sunflower) from: a) diameter of d press matrix and temperature t of raw materials; b) compacting pressure P and temperature t of raw materials; c) compacting pressure P and diameter d press matrix

Table 2. The results of mathematical and statistical analysis of the experiments

Type of raw	Regression equation
Husk of sunflower	$\rho = 155,67 + 7,7184t + 2,356P + 8115,31d + 0,0017t \cdot P + 10,9375t \cdot d + 5,375P \cdot d - 0,02887t^2 - 0,00462P^2 - 241445,31d^2$
Buckwheat of husk	$\rho = 113,358 + 4,787t + 4,571P + 4229,391d + 0,0042t \cdot P - 13,535t \cdot d - 7,734P \cdot d + 0,0773t \cdot P \cdot d - 0,0206t^2 - 0,00852P^2 - 90132,813d^2$
Shavings of pine	$\rho = 293,741 + 5,379t + 3,175P + 8148,875d + 0,00289t \cdot P - 0,02107t^2 - 0,00605P^2 - 209035,156d^2$
Chips of oak	$\rho = 201,88 + 6,654t + 2,6715P + 6159,45d + 0,00114t \cdot P + 8,301t \cdot d + 5,437P \cdot d - 0,024t^2 - 0,00404P^2 - 217667,969d^2$

Straw wheat	$\rho = 35,176 + 6,598t + 3,792P + 7828,813d + 0,00265t \cdot P + 9,328t \cdot d - 0,02585t^2 - 0,0069P^2 - 201035,156d^2$
Wheat bran	$\rho = 330,27 + 2,446t + 3,385P + 2612,5d + 0,00333t \cdot P - 0,0118t^2 - 0,0064P^2 - 90472,6d^2$

IV. Conclusions

The obtained results should be used as a guideline at the organization of the technological process of granulation of dispersed materials by extrusion and at construction of related equipment.

References

- [1] Rindyuk D.V. The method of determination of the optimal parameters of dispersed materials granulation through consolidation / D.V. Rindyuk, S. Y. Lementar // *Food and Environment Safety - Journal of Faculty of Food Engineering, Ștefan cel Mare University - Suceava, Volume XI, Issue 2, Year: 2012 Vol: 11, Issue: 2, pp. 15 -18.*
- [2] Классен Н. П. *Основы техники гранулирования* / Классен Н. П., Гришаев И. Г., Шомин И.П. – М.: Химия, 1982. – 272 с.
- [3] Боголицын К. Г. Экологически безопасные технологии химической переработки древесины / К. Г. Боголицын, Т. Э. Скребец // *The 5th international forum «Aims for future of engineering science»*: Proceeding, May 2-8, 2004. – Paris, France, 2004. – pp.475–478.
- [4] Буров А. В. Органо-сольвентный процесс делигнификации / А. В. Буров, А. В. Бейгельман, Т. Л. Луканина // *Бум. пром-сть*. – 1989. – № 2. – с. 15–16.
- [5] *Практические работы по химии древесины и целлюлозы* / [Оболенская А. В. [и др.]. – М.: Лесн. пром-сть, 1965. – 441 с.
- [6] Скребец Т. Э. Изменение свойств диоксанлигнина после щелочной обработки в присутствии этанола / Т. Э. Скребец, К. Г. Боголицын, Д. Г. Чухчин, С. А. Вербицкая // *Лесн. журн.* – 2004. – № 3. – с. 106–110. – (Изв. высш. учеб. заведений).
- [7] Dahlmann G. Solvent pulping – the no-odor approach to chemical pulping / G. Dahlmann, M. C. Schroeter // *Междунар. симпозиум «PapFor-92»*: тез. докл. – 1992. – С. 297–315.
- [8] Федоров В. В. *Теория оптимального эксперимента (планирование регрессионных экспериментов)* / Федоров В. В. – М.: Наука, 1971. – 312 с.