

**SCI-CONF.COM.UA**

# **SCIENCE, SOCIETY, EDUCATION: TOPICAL ISSUES AND DEVELOPMENT PROSPECTS**

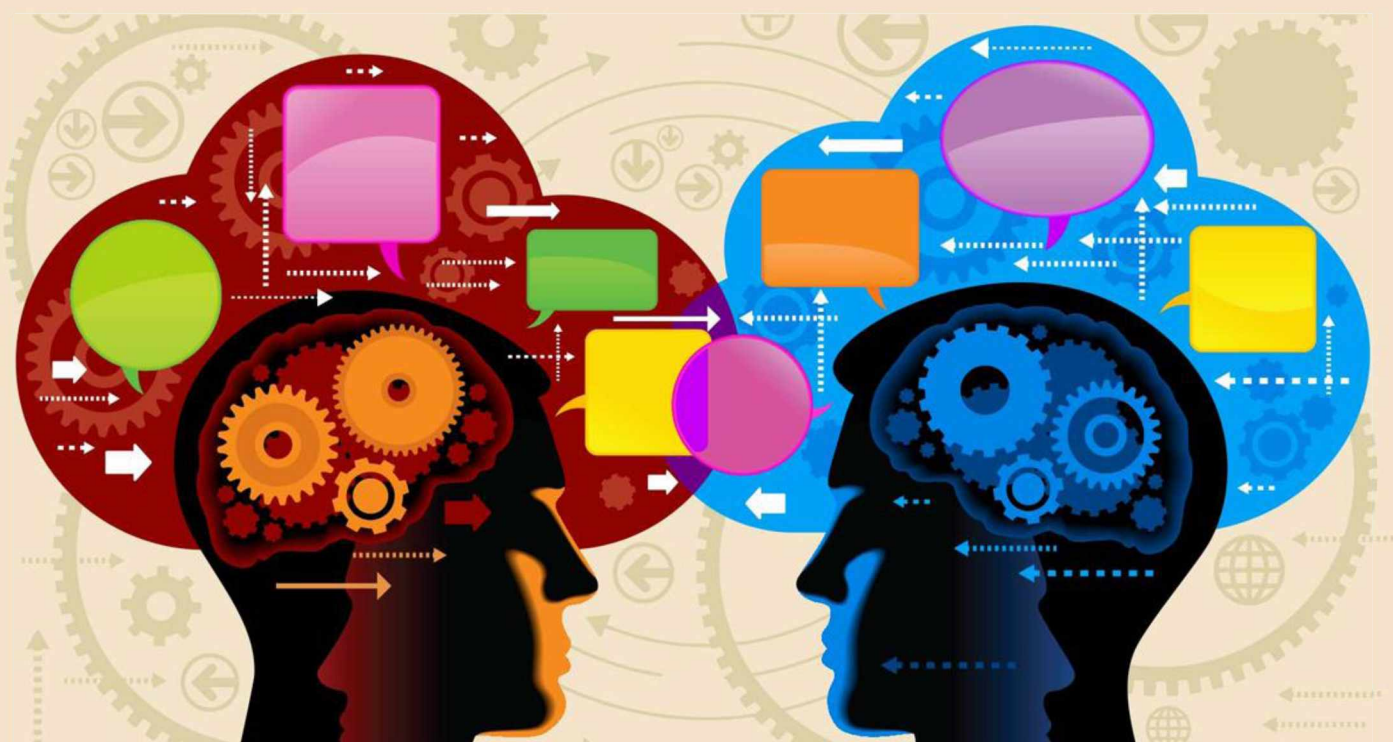

**ABSTRACTS OF III INTERNATIONAL  
SCIENTIFIC AND PRACTICAL CONFERENCE  
FEBRUARY 17-18, 2020**

**KHARKIV  
2020**

# **SCIENCE, SOCIETY, EDUCATION: TOPICAL ISSUES AND DEVELOPMENT PROSPECTS**

Abstracts of III International Scientific and Practical Conference

Kharkiv, Ukraine

17-18 February 2020

**Kharkiv, Ukraine**

**2020**

2

**UDC 001.1**  
**BBK 29**

The 3<sup>rd</sup> International scientific and practical conference “Science, society, education: topical issues and development prospects” (February 17-18, 2020) SPC “Sci-conf.com.ua”, Kharkiv, Ukraine. 2020. 424 p.

**ISBN 978-966-8219-83-2**

The recommended citation for this publication is:

*Ivanov I. Analysis of the phaunistic composition of Ukraine // Science, society, education: topical issues and development prospects. Abstracts of the 3rd International scientific and practical conference. SPC “Sci-conf.com.ua”. Kharkiv, Ukraine. 2020. Pp. 21-27. URL: <http://sci-conf.com.ua>.*

**Editor**

**Komarytskyy M.L.**

*Ph.D. in Economics, Associate Professor*

**Editorial board**

Velichko Ivan Pavlovich (Ukraine)  
Velizar Pavlov, University of Ruse, Bulgaria  
Vladan Holcner, University of Defence, Czech Republic  
Haruo Inoue (Tokyo Metropolitan University)  
Gurov Valeriy Ivanovich (Russia)  
Bagramian Anna Georgievna (Ukraine)  
Pliska Viktoriya Andriyvna (Ukraine)  
Takumi Noguchi (Nagoya University)

Masahiro Sadakane (Hiroshima University)  
Vincent Artero, France  
Ljerka Cerovic, University of Rijeka, Croatia  
Ivane Javakhishvili Tbilisi State University, Georgia  
Marian Siminica, University of Craiova, Romania  
Ben Hankamer, Australia  
Grishko Vitaliy Ivanovich (Ukraine)  
Nosik Alla Vadimovna (Ukraine)

Collection of scientific articles published is the scientific and practical publication, which contains scientific articles of students, graduate students, Candidates and Doctors of Sciences, research workers and practitioners from Europe, Ukraine, Russia and from neighbouring countries and beyond. The articles contain the study, reflecting the processes and changes in the structure of modern science. The collection of scientific articles is for students, postgraduate students, doctoral candidates, teachers, researchers, practitioners and people interested in the trends of modern science development.

**e-mail:** [kharkiv@sci-conf.com.ua](mailto:kharkiv@sci-conf.com.ua)

**homepage:** <http://sci-conf.com.ua>

©2020 Scientific Publishing Center “Sci-conf.com.ua” ®

©2020 Authors of the articles

- 16 Федоренко В. І., Кіцула Л. М. Вплив окремої і комбінованої дії нітратів, нітритів та свинцю на динаміку концентрації SH-груп у сироватці крові лабораторних тварин 71

#### **ФАРМАЦЕВТИЧЕСКИЕ НАУКИ**

- 17 Ezhned M. A., Horoshko O. M., Franko L. V. The use of sprouted grains as one of the ways of a healthy life 76
- 18 Задорожний В. Г., Чулак Л. Д., Чулак О. Л., Чулак Ю. Л. Отримання та дослідження крему на основі амаранту 78

#### **ХИМИЧЕСКИЕ НАУКИ**

- 19 Khokhlov A. V., Kupchyk L. A., Khokhlova L. I. Biocarbon sorbent with high petroleum-degrading ability 82
- 20 Перит В. В. Фізико-хімічний аналіз питної води з артсвердловини при Заліщицькому лісництві 86
- 21 Рудковська О. В., Шепеліна С. І. Оцінка та аналіз впливу вмісту фторидів у питній воді на здоров'я населення Одещини 89

#### **ТЕХНИЧЕСКИЕ НАУКИ**

- 22 Pashchenko V. Perspective method of cleaning water from toxic substances 93
- 23 Зимовець В. І. Інформаційно-екстремальне машинне навчання при багатоінтервальної системі контрольних допусків на ознаки розпізнавання 96
- 24 Лук'янов В. О., Худецький І. Ю., Мельник Г. В. Автоматизована система управління конвекційно-інфрачервоним термохірургічним інструментом 102
- 25 Ніколайчук В. О., Романюк О. В. Новий метод пошуку модифікованих дублікатів зображень у форматі JPEG XR з використанням перцептивних хешів 107
- 26 Орленко С. П. Дослідження динаміки тришарового сферичного куполу з дискретно неоднорідним заповнювачем 111
- 27 Панкратов О. В., Антошкін О. А. Оцінка якості результатів автоматизації роботи інженера-проектувальника систем автоматичного протипожежного захисту 115
- 28 Рубаненко О. Є., Грищук М. О. Визначення часу проведення технічного обслуговування силових трансформаторів за результатами контролю їх частотних характеристик 118
- 29 Скачков В. А., Бережная О. Р., Нестеренко Т. Н., Иванов В. И. Повышение плочности алюминиевых трубок прецизионной точности 121
- 30 Трубнікова А. А., Чабанова О. Б., Шарахматова Т. Є. Розробка технології безлактозного молочного десерту 124

#### **ФИЗИКО-МАТЕМАТИЧЕСКИЕ НАУКИ**

- 31 Волошко О. А. Впровадження інноваційних педагогічних технологій та інтерактивного підходу при викладанні математики 128

# ТЕХНИЧЕСКИЕ НАУКИ

## PERSPECTIVE METHOD OF CLEANING WATER FROM TOXIC SUBSTANCES

**Pashchenko Bohdan**

assistant of Department of Machines and Apparatuses  
for Food and Pharmaceutical Productions  
National University of Food Technologies

**Introduction.** The new technological processes in industry, the using of mineral fertilizers and pesticides in agriculture the shortage and imperfection of water purification facilities reduce the efficiency of wastewater treatment. Most of the toxic pollutants in the water are compounds of chemical and biological origin are discharged into natural reservoirs with industrial and municipal waste water. Traditional water purification technologies do not always provide the necessary sanitary-hygienic requirements. It is necessary the increasing the efficiency of all components of the system of treatment facilities and the using of promising ways to intensify the purification for improving the quality of water purification.

**Aim.** The author is conduct experimental research for determining the effectiveness of the simultaneous action of hydrodynamic cavitation and oxidants on ions of toxic metals with further separation of reaction products on ceramic filtration membranes.

**Materials and methods.** The content of toxic substances in the samples was determined by gas chromatography with previous concentration. A polymer sorbent – tenax – with a specific surface area was used for concentration  $30 \text{ m}^2/\text{g}$ . Water was passed through a soroxial tube with a tenax on which pollutants were adsorbed. The impurities were washed from the sorption tube with an organic solvent and chromatographic analysis of the extract was conduct. Sample analysis was conduct on a “Hewlett Packard” chromatograph in a temperature range  $40 \dots 200 \text{ }^\circ\text{C}$  at

programming 5 °C/min. Quantitative analysis was performed by using of absolute calibration method.

The waste water of galvanic production was subjected by reagent clearing with pH 8.5, which contaminated with ions of heavy and non-ferrous metals. The reagent-oxidant (water solution of  $\text{Ca}(\text{OH})_2$ ) was introduced into the cavitation flow of the environment through the means of creating a cavitation. Water with a similar composition of pollutants was treated in the traditional way for comparison. The sediment, which was formed in the neutralization of toxic pollutants, was separated with using a ceramic membrane module based on  $\text{Al}_2\text{O}_3$  with an internal selective layer based on  $\text{ZrO}_2$ .

The membrane module of the treatment plant (Fig. 1) consists of: fitting 1,5; housing 2, plug 3, sealing rings 4, ceramic ultrafiltration membrane 6. Water was fed under pressure  $P_1 = 0.4$  MPa at a flow rate  $Q = 55$  l/h and at  $P_2 = 0.6$  MPa at a flow rate  $Q = 60$  l/h in accordance. At the same time there was a gradual change in productivity, depending on the duration of the filtration process as a result of sediment compaction on the inner surface of the membrane (Fig. 2).

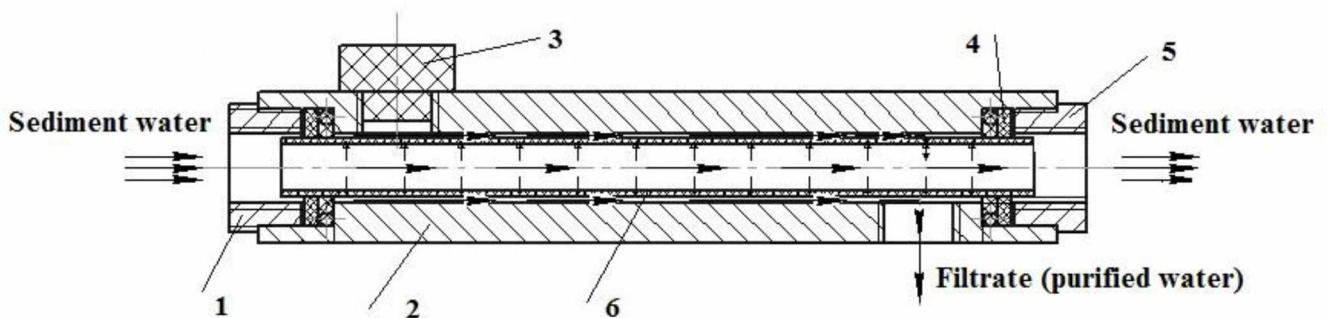

**Fig. 1. Scheme of the cleaning ceramic module: 1, 5 – fitting, 2 – housing, 3 – plug, 4 – sealing rings, 6 – ceramic membrane**

**Results and discussion.** The process of ultrafiltration, which occurred during separation of the sediment, is described by equations of balance. The equation is represented in the form of the law of conservation of the amount of motion with taking into account the law of mass conservation. At the same time for each of the phases the equation of relative motion has the form:

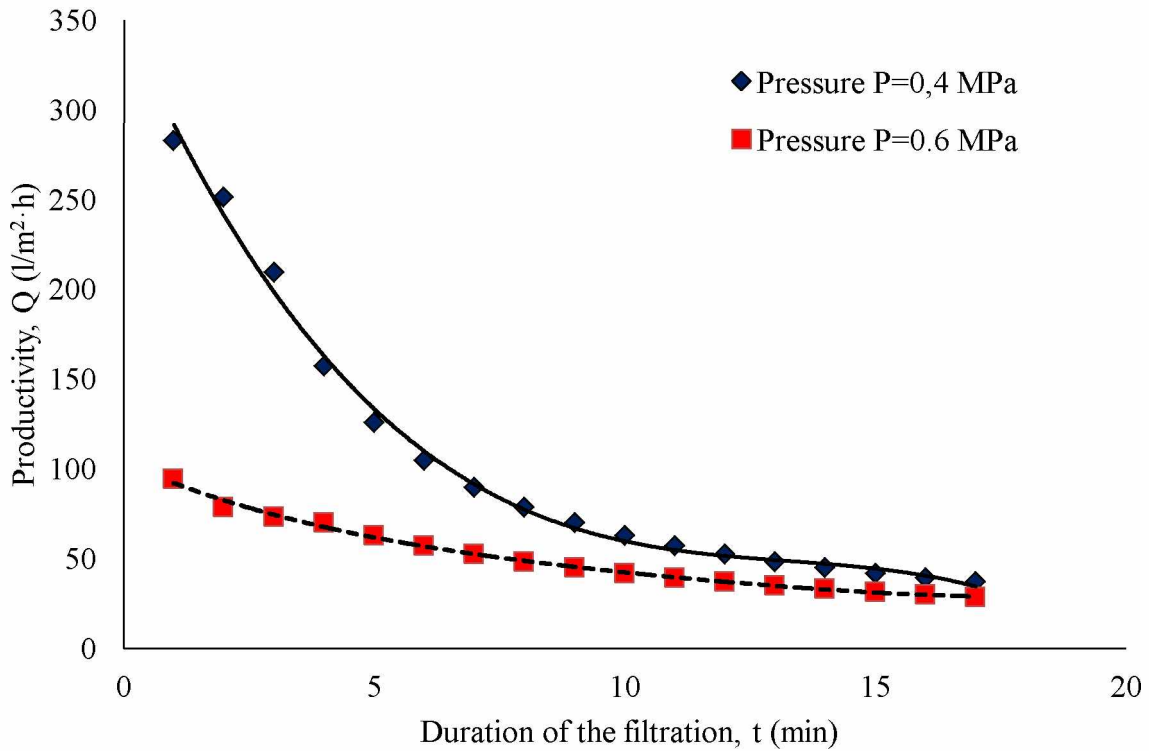

**Fig. 2. Dependence of productivity on the duration of filtration**

$$\alpha_1 \left( \rho_1 \frac{du}{dt} - \rho_2 \frac{dv}{dt} \right) - \nabla \sigma^f - \frac{R}{\alpha_2} - \alpha_1 (\rho_1 - \rho_2) G = 0, \quad (1)$$

$$\rho_2 \frac{dv}{dt} = -\nabla P - \frac{R}{\alpha_2} + \rho_2 G = 0. \quad (2)$$

The force  $R$ , which is proportional to the relative average flow velocity of the fluid, is taken into account in accordance with the specific mechanism of interpenetration of the phases of the system:

$$R = \frac{\mu}{a^2} \alpha_1 \alpha_2 (v-u), \quad (3)$$

where  $\mu$  – coefficient of dynamic viscosity;  $a$  – a generalized coefficient, which taking into account the type of pore material of the membrane.

The purification results are shown in Table 1.

**Table 1****The results of purification of the treatment water**

Composition of pollutants	Waste water before cleaning	Waste water purified in a mechanical stirring reactor	The waste water is purified in a new method
	The content of pollutants, mg/l		
$\text{O}^+$	0,15	0,03	0
$\text{Fe}^{2+}$	2,4	0,01	0
$\text{Fe}^{3+}$	7,8	0,20	traces
Cu	0,04	0	0
Pb	0,05	0	0

**Conclusions.** The author proposes a promising method of wastewater treatment from toxic pollutants. It involves the combined decontamination from ions of heavy and non-ferrous metals in conditions of hydrodynamic cavitation. Further purification was realized out by ultrafiltration on modules with ceramic membranes. The expediency of this method is substantiated and their results are given in comparison with typical cleaning technologies. A more detailed mathematical modeling of the process is planned in the future which is intended for in-depth analysis of deformation of filter elements.