

METHOD OF MATHEMATICAL PLANNING OF EXPERIMENT FOR OPTIMAL FLOWSHEET SELECTION OF BIOCHEMICAL OIL WASTEWATER TREATMENT

O. Semenova, J. Smirnova, N. Bublenco, T. Shylofost

National University for Food Technologies

O. Bublenco

National Transport University

Key words:

Oil wastewater
Biochemical treatment
Factorial experiment plan
Aerotank-clarifier
Pinotank

Article history:

Received 05.01.2013 p.
Received in revised form
18.02.2013
Accepted 10.03.2013

Corresponding author:

E-mail:

govorunchik@ukr.net

ABSTRACT

Oil wastewater includes molecular solutions and hard oxidation coarse impurities. Therefore, wastewater purification is an appropriate step purification scheme. We have used a combined scheme of purification, which includes removal of contaminants in foam layers in gas-liquid conditions. The mathematical experiment planning has been made to select the optimal scheme of biochemical purification. Experimental research of biochemical purification of oil wastewater has been conducted. The advantages of wastewater using a biochemical oxidation unit, which includes an aerotank-clarifier and a pinotank, are outlined.

МЕТОД МАТЕМАТИЧНОГО ПЛАНУВАННЯ ЕКСПЕРИМЕНТУ ДЛЯ ВИБОРУ ОПТИМАЛЬНОЇ ТЕХНОЛОГІЧНОЇ СХЕМИ БІОХІМІЧНОГО ОЧИЩЕННЯ НАФТОВІСНИХ СТІЧНИХ ВОД

О.І. Семенова, Є.С. Смірнова, Н.О. Бублієнко, Т.О. Шилофост

Національний університет харчових технологій

О.В. Бублієнко

Національний транспортний університет

Нафтовмісні стічні води включають молекулярні розчини та важкоокиснювальні органічні речовини. Тому для очищення даних стічних вод доцільно використовувати ступінчасту схему очищення. Нами була застосована комбінована схема очищення, до складу якої входить вилучення забруднень в пінних шарах при газо-рідинній протитечії і окиснення забруднень активним мулом в режимі повного окиснення. Здійснено математичне планування експерименту для вибору оптимальної схеми біохімічного очищення. Проведені експериментальні дослідження процесу біохімічного очищення нафтовмісних стічних вод. Показано переваги очищення стічних вод з використанням блоку біохімічного окиснення, який включає аеротенк-прояснювач і пілотенк.

Ключові слова: *нафтовмісні стічні води, біохімічне очищення, план факторного експерименту, аеротенк-прояснювач, пілотенк.*

Processes of self-purification of open waters are based on biochemical splitting of carbohydrates of oil origin [1].

Experiments conducted in this direction have shown the possibility of biochemical oil splitting and allowed to use artificial oxidation of oil wastewater [2].

Results of experiments on the use of microorganisms to purify oil wastewater of river boats confirmed the possibility of deep marine oil wastewater purification [5].

Selection of the most efficient technological modification of biochemical treatment process is based on the standardized scale schemes that are used in the design of treatment plants of municipal and industrial wastewater [3]. According to this scale selection of optimum scheme is determined by the type and concentration of contaminants.

As a result of experiments and analysis of theoretical studies, oil wastewater includes molecular solutions as well as hard oxidation coarse impurities.

Since oil industrial wastewater contains hard oxidation organic substances which are split at a relatively low rate, a step purification scheme appears to be the most relevant one. The proposed process flowsheet includes physico-chemical and biochemical methods.

The most rational thing will be modification of wastewater purification process, which provides active sludge stabilization. We have used a combined scheme of purification, which includes removal of contaminants in foam layers in gas-liquid countercurrent and oxidation of contaminants by active sludge under full oxidation conditions.

A block of biochemical oxidation consists of two cells connected in series. In fact, none of them is the traditional mixer or propellants.

The engineering solution for the setting's type was found experimentally by analyzing reaction curves related to impulse tracer input during residence time of fluid in the block. The tracer was used as methylene blue.

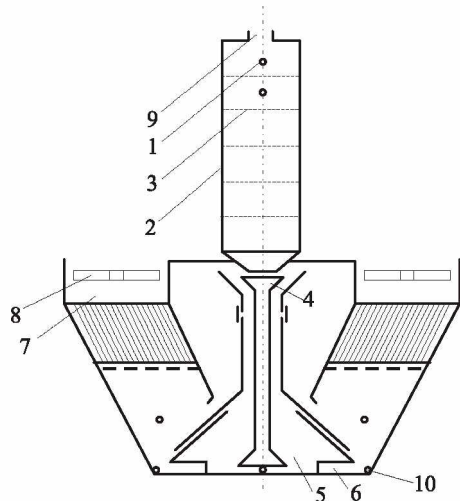

Fig. 1. Scheme of biochemical purification of oil wastewater:

1 — tube, 2 — pinotank, 3 — perforated plates, 4 — steering column, 5 — aeration zone, 6 — aerators, 7 — protection zone, 8 — prefabricated trays, 9 — pipe, 10 — system of holes

The concentration of tracer at the outlet of the setting was determined by optimal density at the turbidimeter [4].

A block of biochemical treatment is a combined setting whose scheme is shown in Fig. 1.

Wastewater enters through the tube (1) into the upper part of pinotank (2), in the same area circulating sludge is carried, which is pumped from the area of clarifying. In pinotank the air passes through the perforated plates (3) to form on their surface foam layers of sludge-water mixture which later through the steering column (4) enters the zone of aeration (5). In the zone of aeration there are aerators (6), through which compressed air is fed from the compressor with the receiver. Areas of aeration, degassing, clarification in airborne layer, thin-layer sedimentation zone and protective zone form together oxidant of the aerotank-clarifier type. From the protective zone (7) purified clarified water is collected by trays (8) and carried away from the setting. Reprocessed air is removed from the pinotank through pipe (9). Releasing of the setting is made through holes system (10) by pipelines. During intensified biochemical purification of oil wastewater the following

technological parameters were determined: rate of contaminants oxidation (removal), absolute, specific and relative increase in sludge, rate oxidation and sludge growth constants, its self-oxidation, oxygen consumption and sludge age. The data obtained during conventional non-intensified wastewater

treatment were considered as controlling. Interdependence between these indicators allows to develop a method for calculating the process of intensified oil wastewater purification and equipment for its efficient implementation.

An indicator of the efficiency of wastewater treatment at the setting may be the rate and completeness of oil products removal. With a relatively stable value of the input oil concentration in the wastewater ($C_0 = 80 \text{ mg/dm}^3$) the effect of their removal (R) determines the quality of treated water, which is normalized by the residual oil concentration (C_1).

The primary factors that determine the value of wastewater treatment optimization, are time and active sludge concentration. Residence time is regulated by wastewater volume that enters the setting and the concentration of sludge by the cost of excess sludge. These parameters determine the intensity of purification in industrial environment, as they are independent from each other.

Optimal conditions for the block operation of biochemical wastewater oxidation were planned according to factorial experiment plan 2^2 [4].

Eight experiments were conducted to establish the levels of factors $t_1 = 6 \text{ h}$, $t_2 = 1 \text{ h}$, $C_1 = 2.3 \text{ g/dm}^3$ and $C_2 = 4.8 \text{ g/dm}^3$, four of them were conducted at the setting aerotank-clarifier and the rest (also four) — at the block of biochemical oxidation (aerotank-clarifier — pinotank).

Levels of factors can be expressed in dimensionless form by encoding them through the scheme:

$$\text{upper value-zero/ variation interval} = \pm 1$$

In the first series of experiments the upper levels of factors have the form of:

$$t_1 = \frac{1-3,5}{2,5} = -1; S_1 = \frac{4,64-3,57}{1,07} = +1; \quad (1)$$

lower levels –

$$t_2 = \frac{6-3,5}{2,5} = +1; S_2 = \frac{2,5-3,54}{1,07} = -1. \quad (2)$$

The results of these experiments can be presented by the incomplete quadratic regression equation

$$R = b + b_1t + b_2C + b_{12}C,$$

where the empirical coefficients (b and Y) for data R , obtained experimentally, regarding signs, equal to:

$$b_0 = \frac{1}{4}(Y_1 + Y_2 + Y_3 + Y_4),$$

$$b_1 = \frac{1}{4}(-Y_1 + Y_2 - Y_3 + Y_4),$$

$$b_2 = \frac{1}{4}(Y_1 - Y_2 - Y_3 + Y_4),$$

$$b_{12} = \frac{1}{4}(-Y_1 - Y_2 + Y_3 + Y_4).$$

from the system of equations data we obtain the regression equation for the two series of experiments:

$$R = 97,83 - 0,123t + 0,023tC + 0,123C, \quad (3)$$

$$R = 98,01 + 0,0375t + 0,2775C + 0,1tC. \quad (4)$$

Statistical analysis of regression equations data has shown that all factors are important and equations are equal to linear model.

Analysis and interpretation of the coefficients in the regression models allow to make a number of conclusions. First, measure of linear effects exposure of residence time at the setting to the depth of wastewater purification in two experiments differ both in magnitude and sign. In the first series of experiments (at aerotank-clarifier) the increase of residence time of wastewater

in the setting reduces the efficiency of its oil wastewater treatment. This is because the silt is gradually ground, self-oxidized and loses its sorption capacity, thus desorption of oil products happens. The coefficients b_1 and b_2 , coincide but are with opposite sign. With increasing the concentration of active sludge the removal effect of oil increases. This is due to an increase in the total adsorption capacity of sludge. Measure of linear interaction of factors expressed by coefficient b_{12} , is much less than linear effects measure.

Thus, the process of oil wastewater treatment at the aerotank-clarifier takes place more efficiently at a shorter residence time for wastewater at the setting and greater concentration of active sludge in it. The minimum residence time value is determined by the calculated hydraulic load on an airborne layer of active sludge and in general for aerotanks-clarifiers it is about 1 hour. The limit for the concentration of active sludge for an aerotank-clarifier is about 5.5 g/dm^3 , but regarding the growth of active sludge in the reactor-mixer, the limit of its concentration should be slightly less.

The interaction of the residence time of wastewater and sludge concentration in the setting block of biochemical oxidation has the impact on oil removal efficiency 4 times as great as that of the aerotank-clarifier. This illustrates the value of the coefficients b_{12} in the relevant equations.

Analysis of regression equations shows that the optimum conditions of the operation of the setting aerotank-clarifier are determined by the coefficients b_1 and b_2 , and of the block aerotank-clarifier and pinotank — by the coefficient b_2 .

Optimal mode in the first series of experiments were at $R = 98.4 \%$, $t = 1 \text{ h}$ and $C = 4.82 \text{ g/dm}^3$. In the second series at the same values of the factors it was 99.86 %.

Therefore, we have selected structural and technological block type of biochemical purification of oil wastewater which was fully confirmed experimentally.

References

1. Жмур Н.С. Технологические и биохимические процессы очистки сточных вод на сооружениях с аэротенками. — М.: Акварос, 2003. — 512 с.
2. Колобанов С.К., Еришов А.В., Кигель М.Е. Проектирование очистных сооружений канализации. — К.: Будівельник, 1977. — 223 с.
3. Комиссаров Ю.А., Цзян Чжицян. Моменты нулевого и первого порядков для любого типа математической модели структуры потока жидкости // Вестник Академии. Информатика, Экология, Экономика. — Т. 12, Ч. 1. — М., 2010. — С. 70 – 77.
4. Методика технологического контроля работы очистных сооружений канализации. — М.: Стройиздат, 1977. — 229 с.
5. Нікітін Г.О., Залевський В.С. Використання мікробіологічного методу для очищення підделаньових вод. — Мікробіол. журн. АН УССР. — № 1, 1976. — с. 38.

МЕТОД МАТЕМАТИЧЕСКОГО ПЛАНИРОВАНИЯ ЭКСПЕРИМЕНТА ДЛЯ ВЫБОРА ОПТИМАЛЬНОЙ ТЕХНОЛОГИЧЕСКОЙ СХЕМЫ БИОХИМИЧЕСКОЙ ОЧИСТКИ НЕФТЕСОДЕРЖАЩИХ СТОЧНЫХ ВОД

Е.И. Семёнова, Е.С. Смирнова, Н.А. Бублиенко, Т.А. Шлюфост

Национальный университет пищевых технологий

А.В. Бублиенко

Национальный транспортный университет

Нефтеcодержащие сточные воды содержат молекулярные растворы и тяжело-окисляемые органические вещества. Поэтому, для очистки данных сточных вод целесообразно использовать ступенчатую схему очистки. Нами была использована комбинированная схема очистки, в состав которой входит извлечение загрязненности в пенных слоях при газо-жидкостном противотоке и окисление загрязнений активным илом в

режиме полного окисления. Осуществлено математическое планирование эксперимента для выбора оптимальной схемы биохимической очистки. Проведены экспериментальные исследования процесса биохимической очистки нефтесодержащих сточных вод. Показаны преимущества очистки сточных вод с использованием блока биохимического окисления, который включает аэротенк-осветлитель и пенотенк.

Ключевые слова: *нефтесодержащие сточные воды, биохимическая очистка, план факторного эксперимента, аэротенк-осветлитель, пенотенк.*