



Kielce University
of Technology



Koszalin University
of Technology



National Academy
of Sciences of Ukraine



Institute of Engineering
Thermophysics



The European Academy
of Education and Science



National Technical
University of Ukraine



University of Zagreb



University of Žilina



Vilnius Gediminas
Technical University

VI International Scientific-Technical Conference

Book of abstracts

ACTUAL PROBLEMS OF RENEWABLE ENERGY, CONSTRUCTION AND ENVIRONMENTAL ENGINEERING

24-27 November 2022, Kielce
(Poland, Ukraine, Croatia, Slovakia, Lithuania)

The time and place of the meeting: 24-27 November 2022
Faculty of Environmental, Geomatic and Energy Engineering
Kielce University of Technology, Poland
al. Tysiąclecia Państwa Polskiego 7, 25-314 Kielce

Beginning of conference: 24 November 2022 in 10:00
Phones for information: +48 41 34 24 850; +48 883 74 12 91
e-mail: apavlenko@tu.kielce.pl, wisge@tu.kielce.pl

Conference languages: Polish, English, Ukrainian

Conference Chairs:

Anatoliy Pavlenko
prof. doctor of science Head of Department of Building Physics
and Renewable Energy, Kielce University of Technology

KIELCE 2022

ISBN 978-83-66678-37-8

COMPARATIVE COMPUTATIONAL ANALYSIS OF THE SELECTION OF BATTERY ENERGY STORAGE FOR CIVIL OBJECTS AND PARKING WITH PHOTOVOLTAIC PLANTS

Petro Zinkevych, Serhii Baliuta, Iuliia Kuievda

National University of Food Technologies, 68 Volodymyrska str., 01601 Kyiv, Ukraine
e-mail: petrozinkevich@gmail.com

Introduction

Energy production from PPS has a number of advantages and disadvantages. One of the disadvantages is that PPS does not produce electricity at night, so they cannot support the load of consumers. To solve the problem of stability of electricity supply at night battery energy storage (BES) are used [1]. BES in combination with a solar power plant is called a battery energy storage system (BESS). This system absorbs and releases energy in different periods. There is no doubt that the additional investment and operating costs of BESS will affect the cost-effectiveness of the PPS.

Materials and Methods

In this study, the selection of the BES and the simulation of the operation modes of the PPS, which is installed on the roof of civil facilities and a parking lot, are carried out. The system consists of PPS, charge controller, inverter and BES. SAM software was used for research.

The structural diagram of the power supply system with PPS and BES is shown in Figure 1.

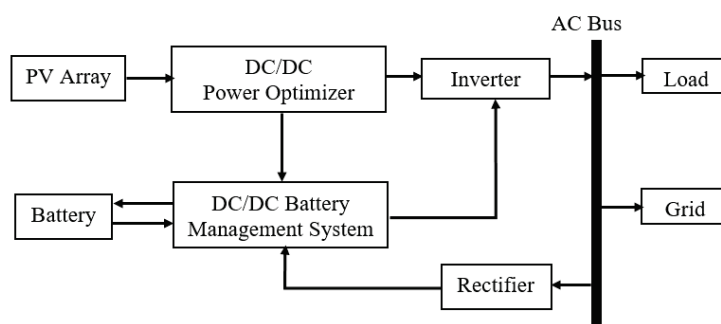

Figure 1. Model of BESS [2].

The principle of operation of BESS is that the energy produced in the PPS charges the BES, and then, when there is no solar insolation, the storage is discharged. At the same time, energy can be used to supply electricity to public housing facilities (parking lots) or can be fed into the electrical grid [3].

The selection of an EE storage unit for an existing PPS involves the following stages:

1. Determining the load capacity of public transport facilities (parking lots).
2. Based on the data on the installed capacity of the PPS, the forecast of the annual EE generation.
3. Calculation of the peak annual load in the SAM software.
4. Calculation of the power and capacity of the BES based on the peak annual load.
5. Choice of BES type: lead-acid or lithium-ion.
6. Selection of the mode of use of the BES.
7. Modeling of BESS operating modes in the SAM software to determine the value of the generated energy of the PPS and evaluate the efficiency of using the BES.

8. Economic analysis and evaluation of the economic performance of the hybrid system using the SAM software, taking into account the daily, monthly and annual volumes of electricity generated by the PPS, BES data and electricity consumed by the facility.

Results and Discussions

It was calculated studies of efficiency using BES for power supply of objects using PPS were carried out. The research objects are located in the city of Kyiv (latitude: 50.4; longitude: 30.45).

Using the calculated parameters of the peak load, the capacity of the BES is determined. The storage was selected taking into account the condition that the peak load should be less than the nominal power of the PPS. A Vipow lithium-ion (lithium-iron-phosphate) battery with a capacity of 50 Ah and a voltage of 3.2 V was selected for the designed PPS. For each object of research using the SAM software, the selection of the choice of BES, the time of operation at maximum power and the capacity BES.

With the use of SAM software, the following modes of operation of the BES were simulated by programming the drive dispatch controller:

1. Mode 1: BES charge during the day, feeds the load in the evening.
2. Mode 2: At night (11:00 p.m. – 7:00 a.m.) it does BES fully charge from the power grid (low electricity tariff), in the morning (7:00 a.m. – 8:00 a.m.) it gives electricity to the electric grid, and then charges from the PPS.

Such working periods are BES defined:

Period 1. All energy from the PPS is directed to battery charging.

Period 2. Discharge of BES and power supply of consumers.

Period 3. Charging of the battery from the electrical grid and subsequent return of energy from the BES to the electrical grid.

It was calculated parameters of BESS, an economic assessment of projects of electricity supply of research objects with the use of PPS was performed.

Analyzing the final data, the results showed that the project with the use of PES for power supply of the parking lot in mode 1 for A4 with a payback period of 10.5 years has the greatest economic efficiency. For civilian objects, the most effective project is the residential building B4-19 with a payback period of 11.3 years and a cost of 219,431 dollars.

Conclusions

1. For the most efficient use of the power supply system with PPS and storage throughout the year, it is advisable to use mode 1, which involves charging the BES during the day, and feeding the load in the evening.
2. Mode 2 should be used to cover the load only during the spring-winter-autumn period, when the generation electricity from the FES is not sufficient.

References

- [1] Salkuti S.R., *Comparative analysis of storage techniques for a grid with renewable energy sources*. Salkuti S.R., Chan M.J., International Journal of Engineering and Technology 2018, Vol. 7, Iss. 3, pp. 970-976.
- [2] Pirthi T., *Performance analysis of pv and bess based hybrid system for residential load volume*. Pirthi T., Tanu P., International Journal of Current Engineering and Scientific Research 2020, Vol. 7, Iss. 3, pp. 18-22.
- [3] Feisal A., *Application of behind the meter battery storage system integrated with net metering in Indonesia*. Feisal A., Sudiarto B., Setiabudy R., IOP Conference Series: Earth and Environmental Science 2020, pp. 1-6.