

## Object-oriented design of packaging machines on the principles of mechatronics

Oleksandr Gavva, Liudmyla Kryvopiias-Volodina,  
Olena Kokhan

*National University of Food Technologies, Kiev, Ukraine*

---

### Abstract

#### Keywords:

Packaging  
Machine  
Mechatronics  
Module  
Graph

---

#### Article history:

Received 24.09.2018  
Received in revised form  
11.11.2018  
Accepted 03.12.2018

---

#### Corresponding author:

Oleksandr Gavva  
E-mail:  
gavvaoleksandr@gmail.com

---

**Introduction.** The research purpose is to formulate the basic principles of object-oriented designing of packaging machines on the basis of mechatronics.

**Materials and methods.** The object of the study is machines for the formation of increased cargo units from group packages. The research method is an object decomposition with the development of logical, physical, static and dynamic models of the projected machine and its object-oriented analysis and synthesis.

**Results and discussion.** Modern multifunctional, high-performance automatic packaging machines are mechatronic systems that consist of four main components: technological, power, information and mechatronic. The development of modern mechatronic packaging machines requires the solving of complex problems, which take into account the interconnections between different components, their reaction to external and internal destabilizing factors.

To solve such problems applying of object-oriented design methods was proposed. The topology of the object-oriented design and technological design of a packaging machine on the basis of mechatronics was developed. In the first stage of the design, the analysis of the technological process of transport package formation was carried out, the basis of the SADT basis was formed the hierarchical structure of the machine, the functional and structural models were developed, the decomposition of the service function of the machine was made, the functional and structural scheme of the machine was developed. Functional-structural scheme of the machine for conducting parametric synthesis with the choice of the best or optimal values of geometric, kinematic, dynamic and energy parameters.

**Conclusions.** The proposed methodology of interactive technologies for designing packaging machines allows to save time on design (up to 45%), to reduce capital costs and to obtain a functionally reliable machine.

DOI: 10.24263/2310-1008-  
2018-6-2-11

---

## Introduction

Since the advent of a new programming ideology, the object-oriented programming languages and object-oriented operating systems have been created. On their base, modern object-oriented automatic design systems (CAD) for solid-state programming (CAD-systems) and for visual design (Visual-system) [1] were developed. The transfer of the ideology of object-oriented programming and the basics of constructing object-oriented CAD systems on traditional designing fields of complex mechanical and technological systems with computer control, which include packaging machines, are not just supplementation. That requires rethinking their design tasks, as at the stage of setting task of designing the system and at all following stages of real design, including at the final stage on the selection of an optimal solution [2].

The most effective solution can be obtained after developing and comparing several variants of mechanical and technological systems. Mostly, the criterion for decision choice is to ensure the minimum cost of the product. At the same time, in today's global society, the need for targeted orientation of scientific research, design and production of packaging equipment of a high level of competitiveness and quality throughout the life cycle of products, are observed. Thus, the development of competitive packaging machines requires the implementation of object-oriented design technology in mechanical engineering industry.

In scientific works [3-5] the actual problem of creating packaging machines based on the functional-modular principle was formulated and currently is solved. But the issue of object-oriented designing machines for the food products packaging previously was not considered by other authors.

The purpose of these research is to form the basic principles of object-oriented design of packaging machines on the basis of mechatronics. According to the purpose, the task is as following :

- to perform analysis of the hierarchical structure of packaging machines as a design object;
- on the basis of SADT design, to construct functionally modular equipment structures in the form of a system description of models: functional (f-model) and structural (s-model);
- to develop a generalized functional-structural scheme of the packaging machine.

## Materials and methods

Modern multifunctional, high-performance automatic packaging machines are mechatronic systems which include four main components: mechatronic, energetic, informational and technological (functional). When designing mechatronic packaging machines, more attention is paid to the first three components [6], and the functional purpose of such machines remains at the level of developing a technological scheme of the packaging process. The task of metric synthesis of packaging machines is the determination of the necessary technological moving of the working parts for the realization of the functional purpose of the machine and for the purpose of automating the main and additional operations.

The development of mechatronic packaging machines requires their modeling. That makes it possible to take into account the interrelations between different components, to investigate the operation of the machine and its reaction to external and internal destabilizing factors without making the physical model of the machine.

To solve such problems it is appropriate to use methods of object-oriented design.

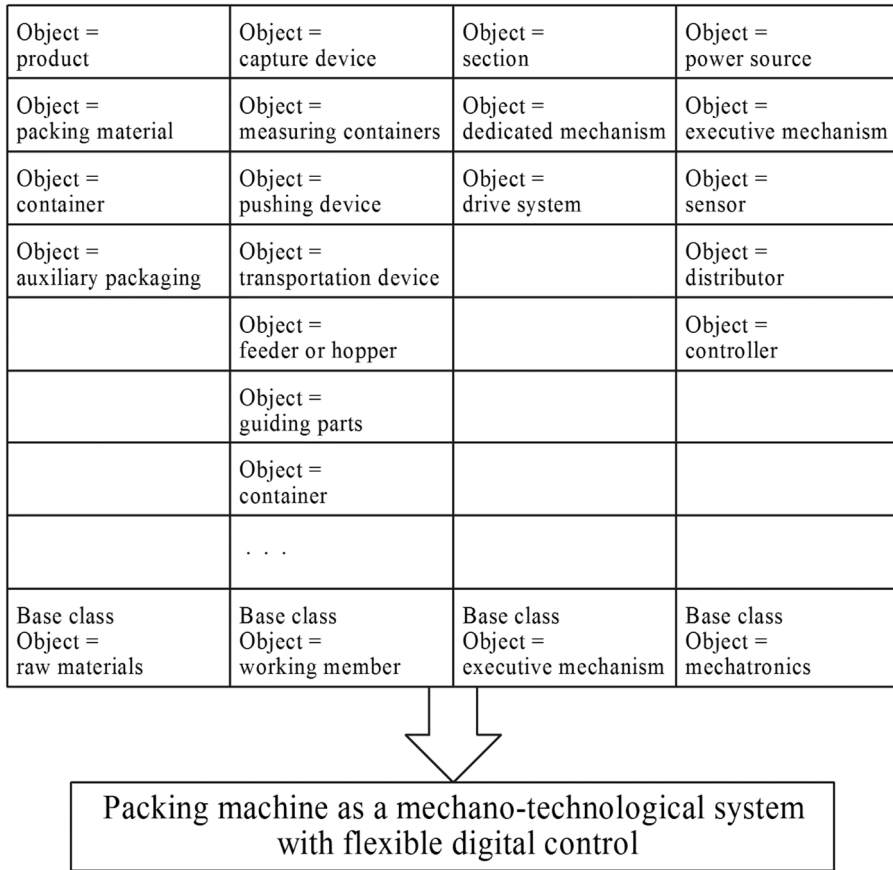

**Figure 1. Topology diagram of object-oriented structural and technological design on the principles of mechatronics**

Object-oriented design (OOD) is a method for designing, combining the process of object decomposition and the reception of the representation of logical and physical, as well as static and dynamic models of the projected packaging machine.

The OOD is based on the models which are formed as a result of object-oriented analysis and synthesis.

Object-oriented analysis is a methodology aimed at creating models using an object-oriented approach based on concepts, classes, and objects.

The main way to solve complex problems in OOD is abstraction. Relations between classes of objects generate hierarchical links.

The OOD process can be summarized as the following sequence:

- Identification of classes and objects of a particular level of abstraction;
- Identification of the semantics of classes and objects;
- Identify the relationships between classes and objects;
- Using classes and objects

For the effective implementation of object-oriented design approach, a Unified Modeling Language (UML) has been developed. UML refers to SADT (Structure Analysis

and Design Technique) - a technology for constructing a functional model for an certain area of objects (packaging machines) [1]. The main purpose of SADT technology is to describe complex objects as hierarchical, multilevel modular systems with a small set of typical elements.

Along with the analysis, object-oriented design involves the implementation of a series of consistent interconnected stages, not iterative descendant structural-parametric synthesis.

Figure 1 shows the scheme of the object-oriented design and technological design of packaging machines on the basis of mechatronics.

Figure 2 shows the topology of object-oriented design and technological design of mechatronic systems of packaging machines.

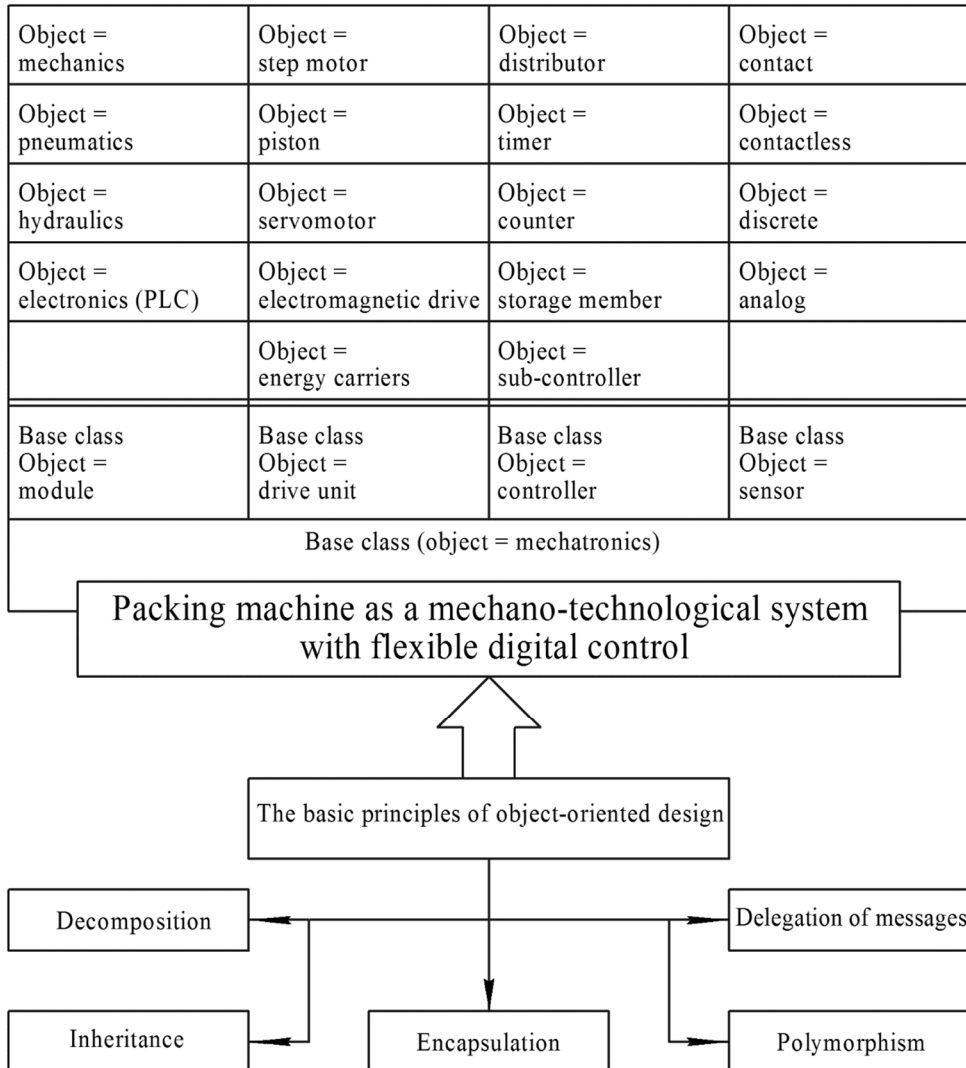

**Figure 2. Topology diagram of object-oriented structural and technological design mechatronic systems of packaging machines**

## Result and discussion

Modern models of packaging machines are complex mechanical and technological systems. They perform a considerable amount of technological processes of packaging. Depending on the technological processes and operations performed, they are divided into classes, subclasses, groups, etc. [4]. Algorithms of object-oriented design are considered on the example of designing a machine for the formation of unit loads from individual items. At the first stage of the design process analysis is carried out, further on the basis of SADT principles the hierarchical structure of the machine is formed, functional and structural models are designed, the operational functions of the machine are decomposed, the hierarchical structure and the functional block diagram of the machine are developed. On the basis of the functional-structural scheme, parametric synthesis is carried out with the choice of the best or optimal values of geometrical, kinematic, dynamic, energy parameters.

Technological process of packaging of unit loads includes the following characteristic operations (by the levels of the graph):

- 1.1. Delivery of single items to the supply conveyor of the batching machine;
- 2.1. Moving items by conveyor;
- 3.1. Profiling of soft transport containers (paper, linen and polymer bags with friable products);
  - 4.1. Individual items orientation;
5. Formation of a row or stop of loads;
  - 5.1. Formation of a line of loads;
  - 5.2. Forming of items pile;
6. Formation of a layer or stack of items;
  - 6.1. Formation of a layer of individual items;
  - 6.2. Formation of a layer from a series of loads;
  - 6.3. Formation of a stack from lines;
  - 6.4. Formation of a stack from piles;
7. Reorientation of the layer or stack;
  - 7.1. Reorientation of the cargo layer to the stack;
  - 7.2. Reorientation of a stack of goods into a layer;
- 8.1. Separation of a single pallet from the stack of the pallets (performed before laying the first in a package of layer or piles of goods);
  - 9.1. Move the unit pallet to the position of the accumulation of the unit load, or to the platform of the lift mechanism.
    - 10.1. Installing or applying auxiliary means of packing (laying of gaskets, applying glue between layers of cargoes, etc.).
11. Formation of the unit load;
  - 11.1 Landing on a stationary pallet or a previously laid layer;
  - 11.2. Stacking of loads in a package;
- 12.1. Fastening of unit load (slings);
  - 13.1. Move the formed unit load from the machine.

The above graph covers all possible ways of forming unit load from the most diverse single consignments. It is pertinent to note that the horizontal method of packet formation is more technologically more efficient for unit load. Therefore, among the many variants of the technological process of the formation of transport packages from tare cargoes, it is possible to distinguish two main groups, the most applied are the groups of processes, the principal difference between these processes is in the method of packing goods in the

package. In the variants of the process carried out for item 11.1, the package itself moves, and in those that pass through position 11.2 only a layer of cargo transactions moves.

After analyzing the structural graph of the technological process of forming the unit load from individual items, the closest to the universal scheme for most individual items and the optimal functional indicators and the cost of the process scheme, the following sequence of operations can be taken:

1. 1.1-2.1-3.0-4.1-5.1-6.1(6.2)-7.0-8.1-9.1-10.0-11.1-12.0-13.1.

This sequence corresponds to the technological process in which the following operations are carried out: overloading the load on the feed conveyor of the palletizer; loading of cargo by a conveyor; the orientation of the cargo; formation of a line of loads; forming a layer of individual items; allocation of a single pallet from a pallet stack and transporting it to the area of the accumulation of the unit load; laying of a layer of goods on an elevating and lowering platform; moving the unit load from the machine:

2. 1.1-2.1-3.0-4.1-5.1-6.1(6.2)-7.0-8.1-9.1-10.0-11.2-12.0-13.1.

The difference of this process is the presence of the operation 11.2 which is stacking of the cargo layer on a fixed pallet or pre-laid layer.

On the basis of the synthesis of the variants of technological processes, it is possible, if necessary, to exclude or replace certain operations, to create the desired type of technological process. So the operation 3.1. is performed only during the packaging of bags with bulk products. In other cases, the process passes through the "3.0" position. The next segment of the chain "4.1-5.1-6.2" corresponds to the case when the cargo is first formed by a row, and then from a row-layer. If in the process of forming a series of cargo orientation is unnecessary, the segment has the form "4.0-5.1-6.2". In the case when the layer is formed immediately from the oriented single items, the process passes through the positions "4.1-5.0-6.1". As for operations "8.1" and "9.1", in most cases they are combined, since the separation of a single pallet from a pallet stack is usually carried out by removing the pallet from the stack and moving its bottom of the formation of the unit load. During forming a unit load without a pallet, the process passes through the positions "8.0" and "9.0" Again, if there is no need for auxiliary means of packaging, the "10.1" position is executed and so on.

Implementation of the technological process of packaging by a robot manipulator is displayed in the following sequence:

- 1.1-2.1-3.0-4.1-5.0(5.1)-6.0(6.1, 6.2)-7.0-8.1-9.1-10.0-11.2-12.0-13.1.

The structure of this process differs from processes 1 and 2 in that the unit load is formed by a robot for individual items (there are no operations 5, 6 and 7). Such process has significant drawbacks—the productivity constraints as a result of the kinematic constraints on the movement of working bodies, the importance of the kinematic and technological cycle of the process and the increased requirements for the deviations of the geometric parameters of the transport packaging.

From the analysis of the design of palletizer, implementing the horizontal method of forming the package, it was established that depending on the design of the hoist of the machine can be divided into three groups: with frame four-column, portal-two-column and single-column completion.

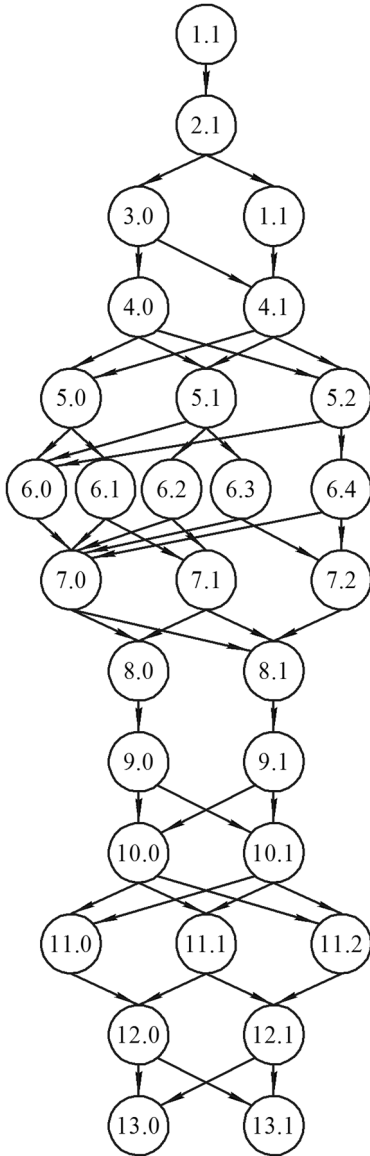

**Figure 3. Structurally-technologic graph of the process of forming a unit load from individual items**

The most wide spread due to its mobility was the frame four-column completion of palletizer. This completion provides a straightforward and similar location of the main functional modules. An important characteristic of the machine completion is the direction of input and output material flows. They can be: direct-current, opposite directed and mutually perpendicular.

The completion of palletizer using functional modules based on the four-column frame construction can fulfill requirements for all directions of cargo flows.

Module as an aggregate unit palletizer is an independent device that performs one or more specific operations of the manufacturing process of the package, fully assembled, functionally verified and ready for installation. The modules can be easily connected by creating complex palletizer schemes, disassembling and modifying them in order to obtain machines of different configurations and with different characteristics.

During the synthesis of structural and design schemes of palletizer, along with the productivity and quality of the package formation, one of the important criteria is the minimal cost of both the equipment itself and its operation. The cost of equipment is proportional to its metal capacity and energy supply. One of the main components of operating costs is the power consumption by equipment, its reliability and flexibility to re-adjust.

That is, the task of structural synthesis is to find such a set of functional modules, so that all technological operations and their elements are performed in a given sequence, and the reliability of the machine should be as high as possible, and the cost does not exceed the maximum permissible value. When designing a machine, it's necessary to take into account that all modules are interconnected, since one and the same function must be carried out by a single module within the machine [6]. The graph of logical connections between the functional modules accepted for consideration is shown in Figure 4

Function modules	Technological operations
	Delivery of single items to the supply conveyor of the batching machine
	Moving items by conveyor
	Orientation individual items
	Formation of a row or stop of loads
	Formation of a layer of items
	Separation of a single pallet from the stack of the pallets
	Move the unit pallet to the position of the accumulation of the unit load
	Formation of the unit load
	Move the formed unit load from the machine

**Figure 4. Graph of logical connections between the functional modules of machines for the formation of transport packages from tare cargoes.**

Formalized representation of the graph is expressed as follows:

$$S : m_1(x_{1.1}) \wedge m_2(x_{2.1}) \vee m_3(x_{3.1}) \wedge m_4(x_{4.0} \vee x_{4.1}) \wedge m_5(x_{5.0} \vee x_{5.1}) \wedge m_6(x_{6.1} \vee x_{6.2}) \wedge m_7(x_{7.1} \vee x_{7.2}) \wedge m_8(x_{8.1}) \wedge m_9(x_{9.1}) \vee m_{10}(x_{10.1}) \wedge m_{11}(x_{11.1} \vee x_{11.2}) \vee m_{12}(x_{12.1}) \wedge m_{13}(x_{13.1})$$

where S - realization of the service function of palletizer (execution of technological operations of packaging); m - technological operations performed by the corresponding functional modules.

On the basis of the developed structural graph of the processes of formation of unit loads from single items and using methods of synthesis and analysis, a rational sequence of



execution of technological operations, functional modules for their realization and logical connections between them are established (Figure 5).

The analysis of the design of palletizer made it possible to develop typical structures of machines corresponding to the structure of the technological process and include functional modules, a system of actuators of executive mechanisms of working parts and the synthesis of control over their work (Figure 6).

The control of the work of all functional modules is provided by the general electronic system, which synchronizes their work in accordance with this packaging process.

In order to implement the latest requirements for the design of palletizer it is appropriate to use an algorithm for constructing a conceptual model based on SADT principles. The algorithm includes the construction of a functional (*f* - model) and structural (*s* - model) models [5].

The graph of the decomposition of the function of the palletizer is shown in Figure 7.

An in-depth description of the conceptual model of palletizer is the construction of S-models. The block diagram of palletizer for unit load is given in the form of "I-OR" trees (Figure 8).

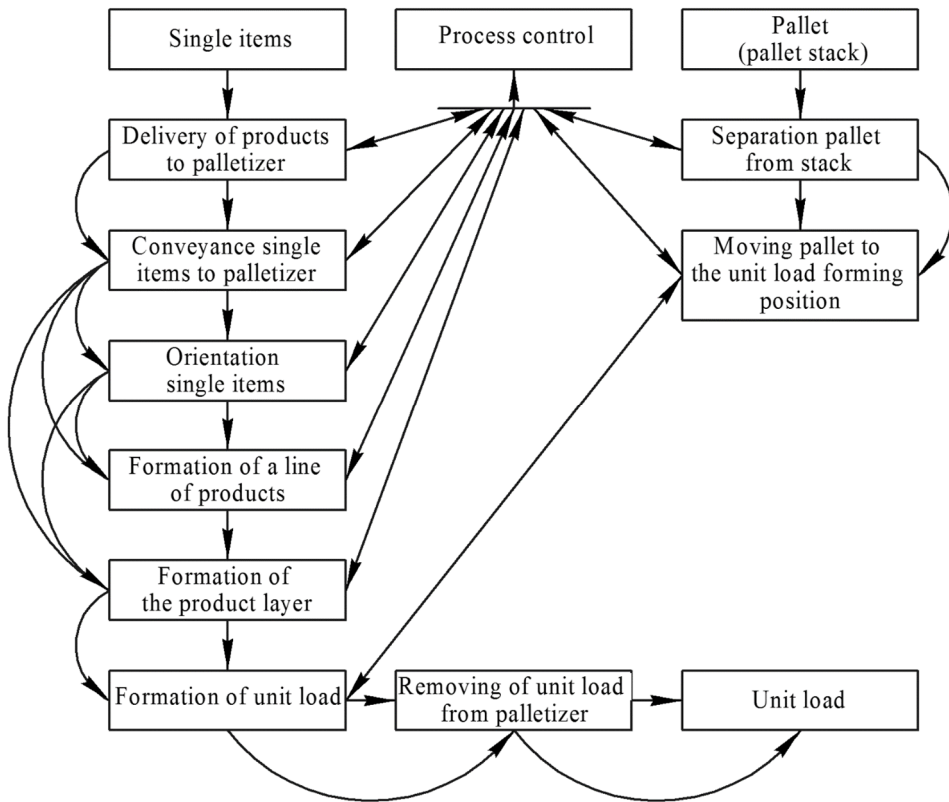

**Figure 5. Logical connections between functional modules in the machines for forming unit load from single items**

On the basis of the developed  $f$  and  $S$  modules, the generalized functional-modular structural schemes of palletizer for various frames constructions, implementing the horizontal method of forming transport packages (Figures 9-11), were developed.

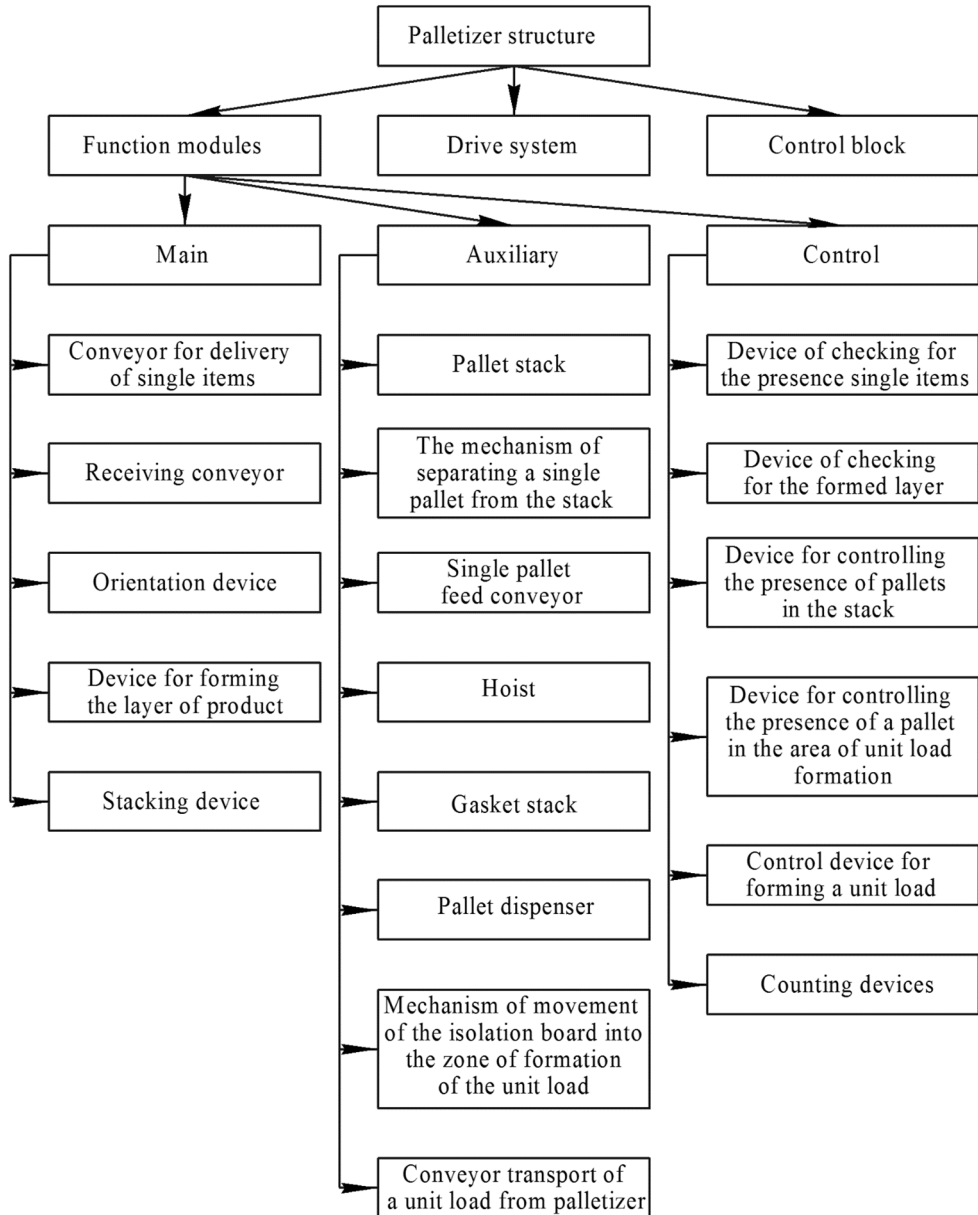

**Figure 6. General structure of the machine for the formation of unit load from single items**

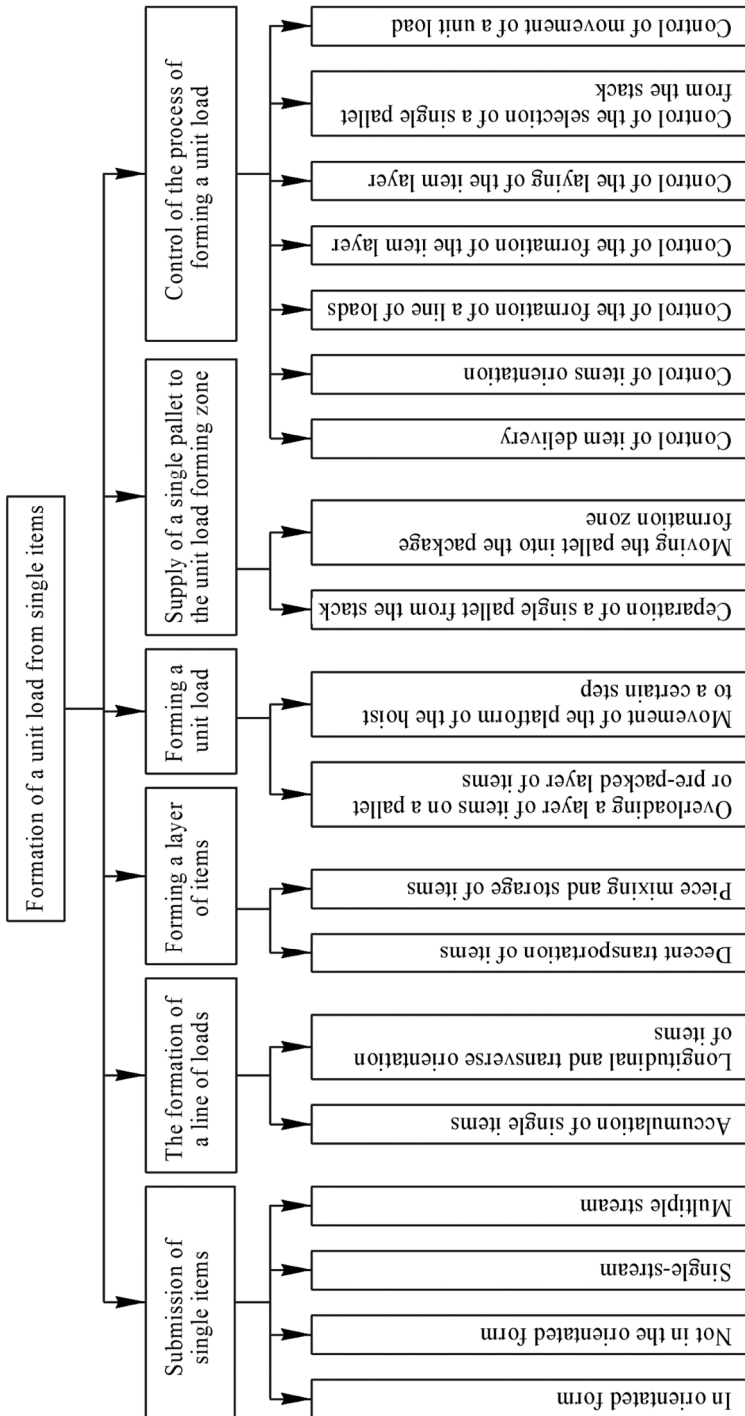
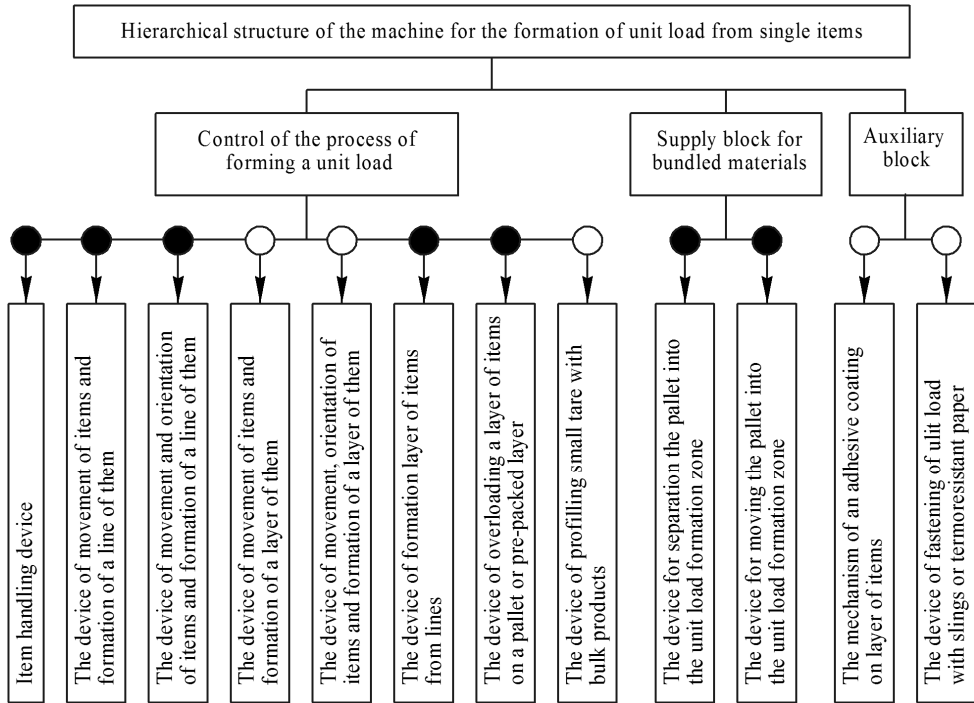
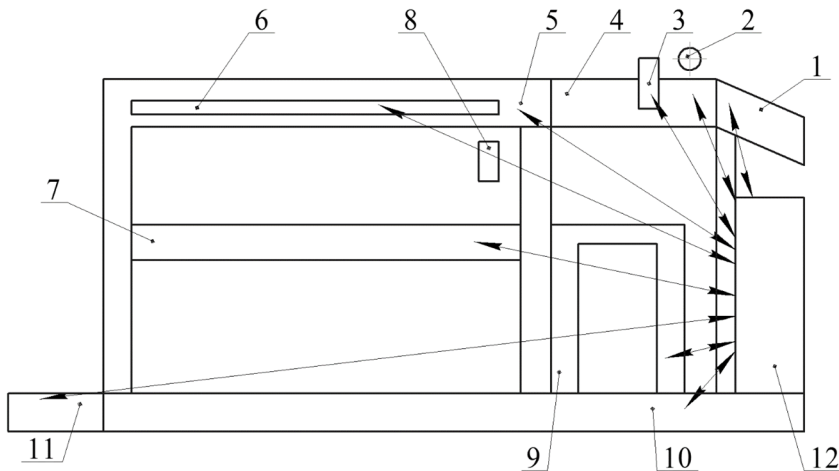

Figure 7. Scheme of decomposition of the service function of the machine for the formation of unit load from single item



**Figure 8. Hierarchical structure of the machine for the formation of unit load from single items:**

● - the vertices are connected "and"; ○ - vertices linked by "or"



**Figure 9. Generalized functional and structural scheme of the machine for the formation of transport packages from containerized cargo with a four-column frame:**

1-conveyor of delivery of freight cargoes; 2 - a device for profiling soft containers; 3 - the device of orientation of tare cargo; 4- conveyor of the formation of a number of loads; 5-device for forming the layer of items; 6-device of collision of a number of loads and packing of a layer of cargoes; 7- lifting and lowering gear; 8. mechanism of applying adhesives to layers of goods; 9- store with pallets; 10 - the conveyor of supply of a single pallet to the lifting gear; 11 - the conveyor of transportation of the formed unit load from the car; 12-block control

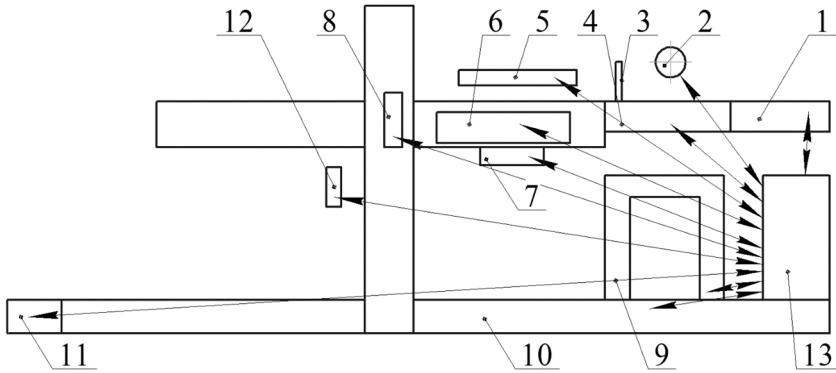

**Figure 10. Generalized functional and structural scheme of the machine for the formation of transport packages from tare cargoes with a two-column frame:**

1-conveyor of delivery of tare cargoes; 2 - a device for profiling soft containers; 3-pointing device for tare cargo; 4-conveyor forming a number of loads; 5 - device of collision of a number of loads and packing of a layer of cargoes; 6. device for forming the layer of goods; 7. The mechanism of horizontal movement of the items layer; 8. lifting and lowering gear; 9- store with pallets; 10 - the conveyor of supply of a single pallet to the lifting gear; 11 - the conveyor of transportation of the formed unit load from the car; 12 - the mechanism of application of adhesives on the layers of items; 13-control unit

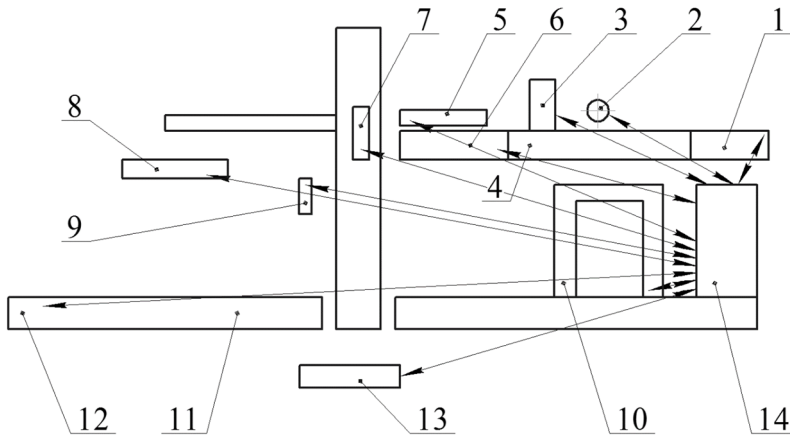

**Figure 11. Generalized functional and structural scheme of the machine for the formation of transport packages of containerized cargo with a single-column frame:**

1-conveyor of delivery of freight cargoes; 2 - a device for profiling soft containers; 3 - the device of orientation of tare cargo; 4- conveyor of the formation of a number of loads; 5 - a device for pushing and sealing a number of loads in a layer; 6-device for forming the layer of goods; 7 - lifting and lowering gear; 8-capture device; 9 - the mechanism of applying adhesives on the layers of items; 10-store with pallets; 11 - the conveyor of delivery of a single pallet to the zone of formation of the unit load; 12 - conveyor of transport of the formed transport package; 13 - the mechanism of rotation of the column; 14 control unit.

To select the optimal structure of the machine for the formation of unit load from single items, consider the sequence of actions of such machines from mechatronic modules in accordance with the functional structure diagram shown in Figure 8

The parametric series of mechatronic modules, forming a functional library, is characterized by execution of the same number of technological operations of the type:

$$L_k = (x_{k1}, x_{k2}, x_{k3}, \dots, x_{kn})$$

where  $x_{kn}$  - module-elements of different nature.

We assume that the structure of equipment for the formation of unit load will consist of a limited set of different types of mechatronic modules, which are subdivided into functional subsystems. The condition for the formation of equipment is as follows:

$$L^{(ln)} = \bigcup_{i=1}^m L_i = \{x / x_{1n} \in L_1 \wedge x_{2n} \in L_2 \vee x_{3n} \in L_3 \vee \dots \wedge x_{mn} \in L_m\}$$

The formation of the structure of a machine for the formation of unit load is carried out by combinatorics, permutations and layouts of various mechatronic modules, forming a set of variants of the same functional scheme of forming a unit load and different structures:

$$N = (L^{(ln)}, L^{(ln)}, L^{(ln)}, \dots, L^{(in)})$$

The search for the optimal variant of the machine complectation, which best corresponds the initial design conditions, involves solving the one-stage or multi-stage optimization synthesis problem by applying well-known techniques [6,7]. For its conduct, an important step is the choice of parameters, or parameters of efficiency and optimization.

## Conclusions

1. On the basis of objectively-oriented design, a topological scheme of a packing machine was developed on the basis of mechatronics. Based on of this scheme, the basic for design structural and control objects of packaging machines was defined.

2. Analysis of mechatronic systems of packaging machines allowed to adapt the basic principles of object-oriented design.

3. Based on the example of formation of unit load from single items, an analysis of their hierarchical structure with the definition of basic, auxiliary, and additional operations was performed.

4. On the basis of SADT principals the functional-modular structures of machines for the formation of cargo unit in the form of functional and structural model were developed.

5. Analysis of functional and structural models of packet forming machines made it possible to perform an optimization synthesis of their combinations .

6. Implementation of the following design stages with the use of interactive technologies allows you to significantly reduce the time spent on design, capital costs and obtain a reliable operation of the machine.

## References

1. Grady Buch, Robert A. Maksymchuk, Michael W. Engle, Bobbie J. Young, Jim Konallen, Kelly A. Houston (2008), *Object-Oriented Analysis and Design with Application. 3th edition*, I. D. Williams.

2. Orlovskyy B.M. (2018), *Mekhatronika v haluzevomu mashynobuduvanni*, KNUTD, Kyiv.
3. Palchevskyy B.O., Shapoval O.M., Velykyy O.A. (2013), *Optyimizatsiynyy syntez funktsionalno-modulnoyi struktury pakuval'noho ustatkuvannya*, Lutsk National Technical Universiti, Lutsk.
4. Gavva O.M., Volchko A.I., Bespalko A.P., Kokhan O.O. (2010), *Pakuvalne obladnannya*, Upakovka, Kyiv.
5. Gavva O.M. (2015), *Funktsionalno-modulne proektuvannya pakuvalnykh mashyn: monograph*, Stal, Kyiv.
6. Yakymchuk N.V., Gavva O.M., Bespalko A.P (2017), *Proektuvannya pakuval'noho obladnannya iz mekhatronnykh moduliv*, Stal, Kyiv.
7. Bogdan Palchevsky, Anton Shvits, Volodymyr Pavlin (2014), *Informatsiyne zabezpechennya intehrovanykh hnuchkyy informatsiynykh system: monograph*, Vezha-druk, Kyiv.
8. Johannes Bräuer, Reinhold Plösch, Matthias Saft, Christian Körner (2018), *Measuring object-oriented design principles: The results of focus group-based research*, *Journal of Systems and Software*, 140, pp. 74-90.
9. Suhel Ahmad Khan, Raees Ahmad Khan (2012), *Analyzability Quantification Model of Object Oriented Design*, *Procedia Technology*, 4, pp. 536-542
10. Shiva Abdoli, Sami Kara (2016), *Designing Warehouse Logical Architecture by Applying Object Oriented Model Based System Engineering*, *Procedia CIRP*, 50, pp. 713-718
11. Peter E. D. Love, Jingyang Zhou, Jane Matthews, Hanbin Lou (2016), *Object oriented modeling: Retrospective systems information model for constructability assessment*, *Automation in Construction*, 71(2), pp. 359-371